

FENDER REPAIRS AT PIER 1, 2 AND TUG PIER KAHULUI HARBOR, MAUI, HAWAII

FOR THE
STATE OF HAWAII
DEPARTMENT OF TRANSPORTATION
HARBORS DIVISION

S30215

CONSULTANT:

MKE ASSOCIATES LLC
STRUCTURAL ENGINEER

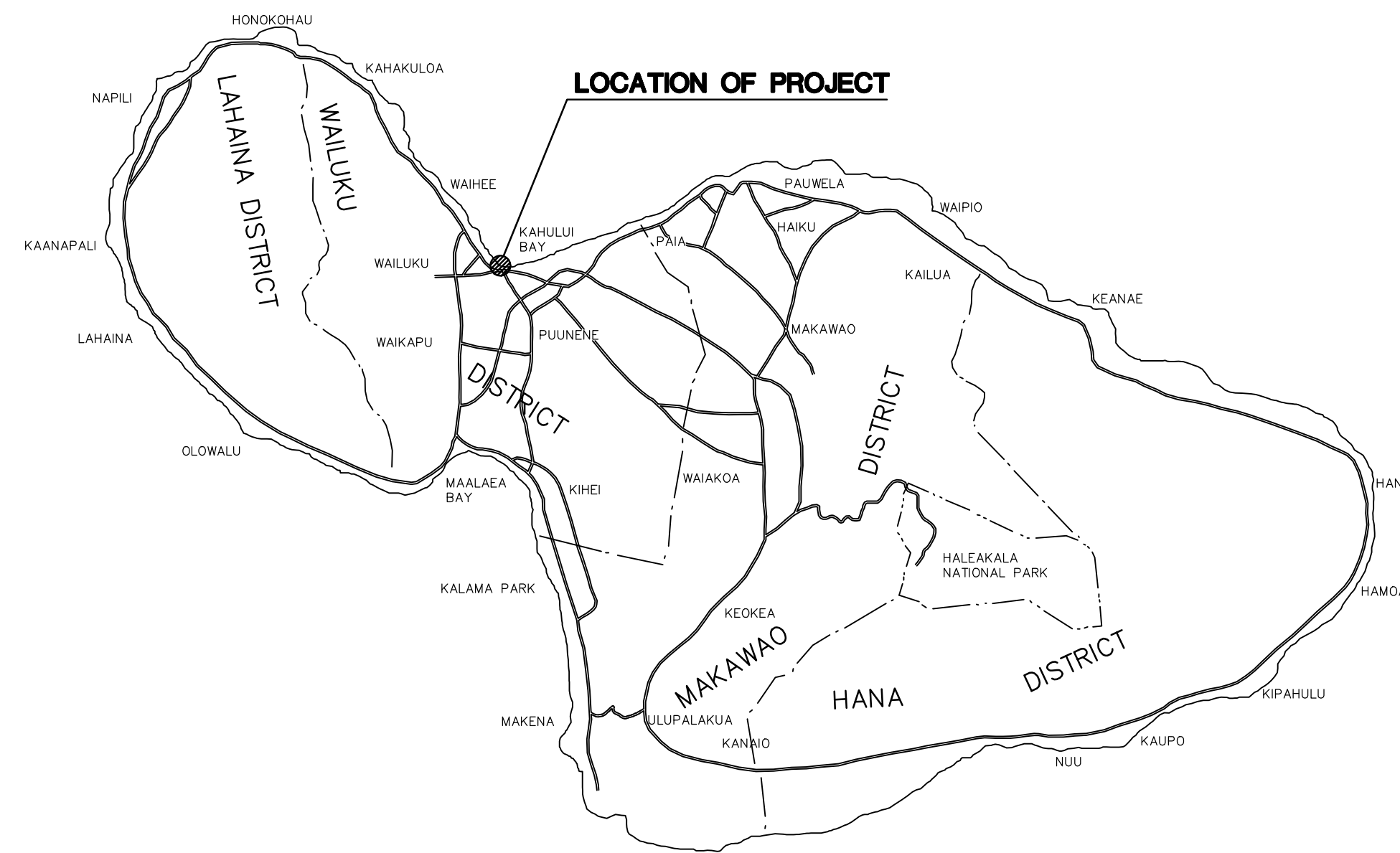

ISLAND OF MAUI

LOCATION MAP

NOT TO SCALE

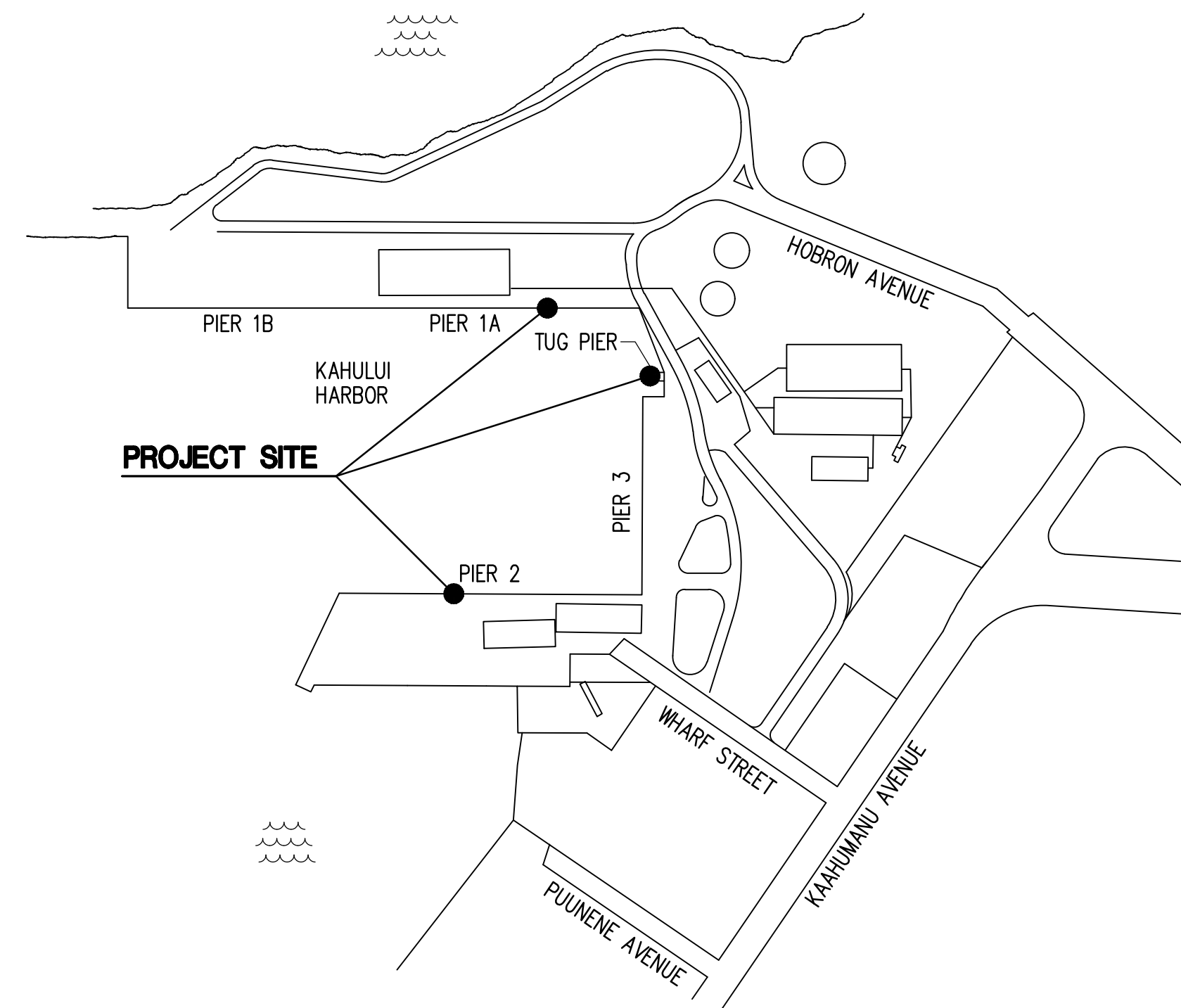
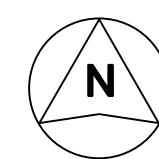

VICINITY MAP

NOT TO SCALE

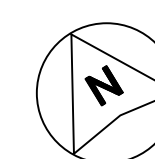

DEPARTMENT OF TRANSPORTATION STATE OF HAWAII		SHEET T-1
APPROVED BY: 	May 1, 2023	
FOR DIRECTOR OF TRANSPORTATION		DATE 1 of 13 SHEETS

INDEX TO DRAWINGS

SHEET NO.	TITLE
T-1	TITLE SHEET, LOCATION AND VICINITY MAPS
T-2	INDEX TO DRAWINGS AND GENERAL PLAN
S-1	STRUCTURAL NOTES
S-2	EXISTING PARTIAL PIER 1 PLAN AND ELEVATION
S-3	PARTIAL PIER 1 REPAIR PLAN AND ELEVATION
S-4	EXISTING PARTIAL PIER 2 PLAN AND ELEVATION
S-5	PARTIAL PIER 2 REPAIR PLAN AND ELEVATION
S-6	TUG PIER PLAN AND ELEVATION
S-7	PIER 1 SECTIONS
S-8	PIER 2 SECTIONS
S-9	TUG PIER SECTION
S-10	FENDER DETAILS
S-11	PIER 1 AND 2 HAUNCH REPAIRS

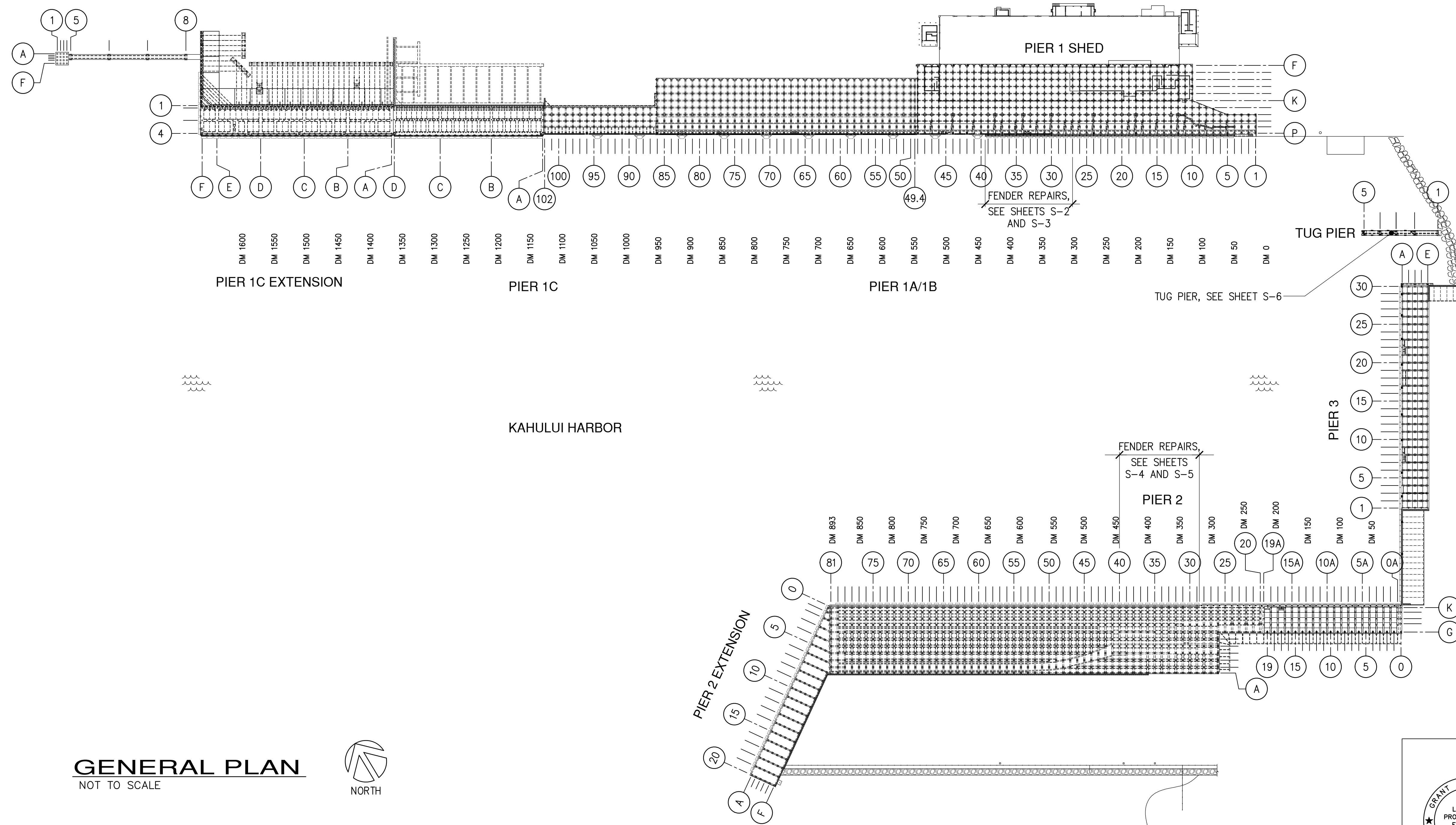

GENERAL PLAN
NOT TO SCALE

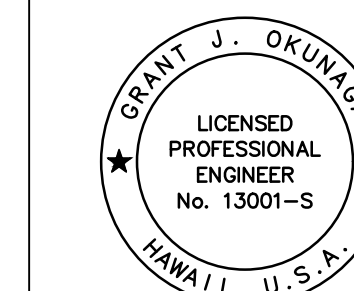

THIS WORK WAS PREPARED BY ME
OR UNDER MY SUPERVISION
EXP. 4-30-24
Grant J. Okunaga
MKE ASSOCIATES LLC

REVISION	DATE	DESCRIPTION	BY	APPROVED
STATE OF HAWAII DEPARTMENT OF TRANSPORTATION HARBORS DIVISION				
JOB TITLE FENDER REPAIRS AT PIER 1, 2 AND TUG PIER KAHULUI HARBOR, MAUI, HAWAII				
SHEET TITLE INDEX TO DRAWINGS AND GENERAL PLAN				
DESIGNED BY: GO	JOB NUMBER S30215		SHEET T-2	
DRAWN BY: DL				
CHECKED BY: GM				
DATE: 04/2023				
SCALE: AS SHOWN			2 OF 13 SHTS.	

STRUCTURAL NOTES:

GENERAL:

- WORKMANSHIP AND MATERIALS SHALL CONFORM TO THE HAWAII STANDARD SPECIFICATION FOR ROAD AND BRIDGE CONSTRUCTION, 2005, FOR THE STATE OF HAWAII, UNLESS OTHERWISE INDICATED. HOWEVER, WHERE REFERENCE IS MADE TO PERFORMANCE CONFORMING TO OTHER STANDARDS THE MORE STRINGENT SHALL APPLY.
- THE CONTRACTOR SHALL COMPARE PLANS, SPECIFICATIONS AND ALL OTHER CONTRACT DOCUMENTS WITH EACH OTHER AND REPORT IN WRITING TO THE HARBORS DIVISION CONSTRUCTION ENGINEER ALL INCONSISTENCIES AND OMISSIONS.
- THE CONTRACTOR SHALL TAKE FIELD MEASUREMENTS AND VERIFY FIELD CONDITIONS AND SHALL COMPARE SUCH FIELD MEASUREMENTS AND CONDITIONS WITH THE DRAWINGS BEFORE COMMENCING WORK. REPORT IN WRITING TO THE HARBORS DIVISION CONSTRUCTION ENGINEER ALL INCONSISTENCIES AND OMISSIONS.
- CONTRACTOR SHALL RESOLVE ANY DISCREPANCIES AND QUESTIONS PRIOR TO THE START OF WORK. NO EXTRA PAYMENT SHALL BE ALLOWED ON ACCOUNT OF WORK MADE NECESSARY BY CONTRACTORS FAILURE TO VISIT THE SITE AND/OR FAILURE TO RESOLVE DISCREPANCIES AND QUESTIONS.
- THE CONTRACTOR SHALL PROTECT ALL UTILITIES AND STRUCTURES IN AND ADJACENT TO THE PROJECT SITE. ANY DAMAGE SHALL BE REPAIRED TO THE SATISFACTION OF THE HARBORS DIVISION CONSTRUCTION ENGINEER AND PAID FOR BY THE CONTRACTOR.
- THE CONTRACTOR SHALL BE RESPONSIBLE FOR COORDINATING THE WORK OF ALL TRADES.
- THE CONTRACTOR SHALL COORDINATE HIS/HER WORK WITH OTHER CONTRACTORS WITHIN THE PROJECT AREA. THE CONTRACTOR SHALL ALSO COORDINATE WITH THE HARBORS DIVISION MAUI DISTRICT MANAGER AND CONSTRUCTION ENGINEER FOR AN APPROVED STAGING AND STORAGE AREA AND FOR RESTRICTIONS OF HARBORS OPERATIONS OVER REPAIR AREAS.
- THE CONTRACTOR SHALL REMOVE ALL DEBRIS RESULTING FROM HIS/HER WORK AS REQUIRED FOR PUBLIC HEALTH AND SAFETY AND TO THE SATISFACTION OF THE HARBORS DIVISION CONSTRUCTION ENGINEER. SHOULD THE STATE PERFORM ANY OF THE ABOVE WORK DUE TO NON-PERFORMANCE BY THE CONTRACTOR, THE CONTRACTOR AGREES TO REIMBURSE THE STATE FOR ALL COSTS INCURRED.
- HARBOR OPERATIONS TAKE PRECEDENCE OVER CONSTRUCTION ACTIVITY. THE CONTRACTOR MUST WORK AROUND HARBOR OPERATIONS SO THAT THE PIERS WILL REMAIN OPERATIONAL. WEEKEND WORK MAY BE REQUIRED AND SHALL BE COORDINATED WITH THE HARBORS DIVISION CONSTRUCTION ENGINEER AND TENANTS IN ADVANCE.
- THE CONTRACTOR SHALL BE RESPONSIBLE FOR METHODS OF CONSTRUCTION, WORKMANSHIP AND JOB SAFETY. THE CONTRACTOR SHALL PROVIDE TEMPORARY SHORING AND BRACING AS REQUIRED FOR STABILITY OF STRUCTURAL MEMBERS AND SYSTEMS.
- ALL WORK SPECIFIED IN THE CONTRACT BUT NOT LISTED SEPARATELY SHALL BE CONSIDERED INCIDENTAL AND WILL NOT BE PAID FOR SEPARATELY.
- NOTES AND DETAILS ON THE PLANS SHALL TAKE PRECEDENCE OVER GENERAL NOTES AND TYPICAL DETAILS. SHOULD THERE BE CONFLICTS BETWEEN THE REQUIREMENTS OF THE PLANS OR SPECIFICATIONS, THE MORE STRINGENT SHALL APPLY.
- THE CONTRACTOR SHALL COMPLY WITH THE CLEAN WATER ACT AND THE STATE HARBORS DIVISION STORMWATER MANAGEMENT PROGRAM. NO POLLUTANTS ARE ALLOWED TO BE DISCHARGED DIRECTLY OR INDIRECTLY THROUGH THE HARBORS SMALL MS4 OR OTHER POTENTIAL PATHWAY INTO HARBOR WATERS.
- THE CONTRACTOR WILL BE RESPONSIBLE FOR REGULATORY FINES OR PENALTIES THAT MAY BE IMPOSED BY ENVIRONMENTAL REGULATORY AGENCIES (EPA AND/OR STATE DOH) IN THE EVENT OF VIOLATIONS.
- THE CONTRACTOR SHALL SUBMIT A SITE-SPECIFIC BEST MANAGEMENT PRACTICES (BMP) PLAN TO HARBORS DIVISION ENGINEER BRANCH PRIOR TO THE START OF ANY CONSTRUCTION WORK. THE SITE SPECIFIC BMP PLAN SHALL COMPLY WITH ENVIRONMENTAL PROTECTION AND TEMPORARY WATER POLLUTION, DUST, AND EROSION CONTROL ARTICLES IN THE SPECIFICATIONS AND PROPOSAL.
- IN CASE OF SPILL, LEAK, OR OTHER RELEASE CONTAINING A HAZARDOUS SUBSTANCE OR OIL, THE CONTRACTOR SHALL NOTIFY APPROPRIATE FACILITY PERSONNEL, EMERGENCY RESPONSE AGENCIES, AND REGULATORY AGENCIES FOLLOWING NOTIFICATION PROCEDURES, AND SHALL NOTIFY THE HARBORS DIVISION CONSTRUCTION ENGINEER IMMEDIATELY (I.E. WITHIN 24 HOURS). SUCH CONTACT INFORMATION MUST BE IN LOCATIONS THAT ARE READILY ACCESSIBLE AND AVAILABLE.
- TIDAL DATA MAY NOT REPRESENT CONDITIONS THAT OCCUR DURING CONSTRUCTION AND ACTUAL WATER LEVELS WILL VARY FROM LEVELS INDICATED. THE CONTRACTOR IS RESPONSIBLE FOR MAKING THEIR OWN ESTIMATES OF WATER LEVELS WHICH MAY OCCUR DURING CONSTRUCTION. VARIATION FROM TIDAL LEVELS INDICATED OR CONTRACTOR'S ESTIMATION OF TIDAL LEVELS WILL NOT BE CONSIDERED AS A CLAIM FOR ADDITIONAL COMPENSATION OR DELAY OF WORK.

CONCRETE:

- CONCRETE CONSTRUCTION SHALL CONFORM TO AMERICAN CONCRETE INSTITUTE ACI 318R-14 AND ACI 546R-14.
- FORMED CONCRETE SHALL HAVE A 28-DAY COMPRESSIVE STRENGTH OF $f'_c=5,000$ PSI WITH SILICA FUME AND CORTEC MCI 2005 NS MIGRATING CORROSION INHIBITING ADMIXTURE, OR APPROVED EQUAL.
- MAXIMUM AGGREGATE SIZE SHALL BE $\frac{3}{4}$ INCHES AND SHALL BE COORDINATED WITH CONCRETE PREPARATION PROCEDURES FOR SPALL REPAIRS.
- CONCRETE DELIVERY TICKETS SHALL RECORD ALL FREE WATER IN THE MIX: AT BATCHING BY PLANT, FOR CONSISTENCY BY DRIVER, AND ANY ADDITIONAL REQUEST BY CONTRACTOR IF PERMITTED BY THE MIX DESIGN.
- MAXIMUM WATER TO CEMENTITIOUS MATERIALS RATIO SHALL BE 0.40.
- PATCHING COMPOUND FOR FORM AND POUR SPALL REPAIRS SHALL BE SIKACRETE 211 SCC PLUS BY SIKA, OR APPROVED EQUAL.
- PATCHING COMPOUND FOR REPAIRING VERTICAL AND SOFFIT SPALLS IN LIFTS SHALL BE SIKAQUICK VOH WITH LATEX R BY SIKA, OR APPROVED EQUAL.
- REINFORCING BARS, ANCHOR BOLTS, INSERTS, AND OTHER ITEMS TO BE CAST IN THE CONCRETE SHALL BE SECURED IN POSITION PRIOR TO PLACEMENT OF CONCRETE.

REINFORCING STEEL:

- REINFORCING STEEL FOR WELD SPLICING SHALL BE ASTM A706 GRADE 60. WELDING ELECTRODES SHALL BE LOW HYDROGEN E70.
- REINFORCING STEEL NOT TO BE WELD SPLICED SHALL BE ASTM A615, GRADE 60 OR ASTM A706 GRADE 60.
- CLEAR CONCRETE COVER FOR REINFORCING BARS SHALL BE 3 INCHES MINIMUM, UNLESS OTHERWISE NOTED.
- BAR BENDS AND HOOKS SHALL BE STANDARD HOOKS IN ACCORDANCE WITH ACI 318.
- REINFORCING STEEL SHALL BE SPLICED AS INDICATED ON PLANS. PROVIDE WELD SPLICE PER TYPICAL DETAILS, UNLESS OTHERWISE NOTED.
- ANTI-CORROSION COATING WITH A MINIMUM 7 DAY OPEN TIME FOR REINFORCING STEEL SHALL BE ARMADEC 110 EPOCEM BY SIKA OR APPROVED EQUAL.
- EPOXY FOR GROUTING OF DOWELS SHALL BE SET-3G BY SIMPSON STRONG-TIE, OR APPROVED EQUAL.
- TIE WIRE SHALL BE PLASTIC-COATED, STAINLESS STEEL, OR MADE OF DIELECTRIC OR OTHER ACCEPTABLE MATERIAL. ALL LOOSE REINFORCING STEEL SHALL BE SECURED WITH TIES AT ALL INTERSECTIONS WITH ADJACENT REINFORCING STEEL.

FENDER SYSTEM:

- FENDER HARDWARE INCLUDING SHACKLES, ANCHOR PINS, CHAINS, GROMMETS AND MISCELLANEOUS ITEMS EXCEPT COTTER PINS SHALL BE HOT-DIPPED GALVANIZED PER ASTM A-123.
- COTTER PINS SHALL BE STAINLESS STEEL.
- FABRICATION AND ERECTION OF STRUCTURAL STEEL SHALL CONFORM TO THE AMERICAN INSTITUTE OF STEEL CONSTRUCTION MANUAL OF STEEL CONSTRUCTION, FIFTEENTH EDITION. ALL STEEL SHALL BE HOT-DIPPED GALVANIZED UNLESS OTHERWISE NOTED.
- STRUCTURAL STEEL SHALL CONFORM TO ASTM A36 UNLESS OTHERWISE NOTED.
- STEEL PIPES SHALL CONFORM TO ASTM A53, GRADE B.
- TIRES SHALL BE FURNISHED BY THE CONTRACTOR AND SHALL BE FREE OF RIPS, TEARS OR OTHER SIGNIFICANT DAMAGE TO THE SATISFACTION OF THE CONSTRUCTION ENGINEER
- ALL STRUCTURAL MEMBERS SHALL BE ROUGH SAWN, UNLESS NOTED OTHERWISE.
- WALERS FOR FENDER SYSTEM REPAIRS SHALL BE BAR AND FIBER REINFORCED MOLDED LUMBER MANUFACTURED BY TANGENT TECHNOLOGIES, LLC OR APPROVED EQUAL AS INDICATED ON THE PLANS.
- ALL BOLTS, NUTS, NAILS AND MISCELLANEOUS CONNECTION HARDWARE FOR FENDER SYSTEM REPAIRS SHALL BE TYPE 316 STAINLESS STEEL.

PREPARATION OF SUBSTRATE AND REINFORCING STEEL FOR SPALL REPAIRS:

- SURFACE PREPARATION FOR SPALL REPAIRS SHALL FOLLOW THE INTERNATIONAL CONCRETE REPAIR INSTITUTE (ICRI) GUIDELINE NO. 310.1R-2008.
- BOTH SPALLS AND DELAMINATIONS ARE REFERRED TO ON THE DRAWINGS AS "SPALLS", AS THE REPAIR PROCEDURES ARE THE SAME FOR BOTH CONDITIONS.
- THE CONTRACTOR SHALL SOUND ALL CONCRETE SURFACES TO IDENTIFY SPALLS AND DELAMINATIONS.
- ANY ELEMENT BEING REPAIRED SHALL NOT BE SUBJECTED TO LIVE LOADS DURING THE PERIOD STARTING FROM THE REMOVAL OF EXISTING CONCRETE UNTIL THE REPAIR CONCRETE HAS OBTAINED A MINIMUM COMPRESSIVE STRENGTH OF 4,000 PSI.
- PREPARATION OF SUBSTRATE AND REINFORCING STEEL FOR SPALL REPAIRS SHALL BE PERFORMED IN THE ORDER LISTED BELOW.
- THE SPALLED AND DELAMINATED CONCRETE SHALL BE COMPLETELY REMOVED TO SOUND SUBSTRATE AND BEYOND THE EXTENT OF THE CORRODED REINFORCING. THE CONTRACTOR SHALL TAKE THE NECESSARY PRECAUTIONS TO AVOID DAMAGING THE UNDERLYING SOUND CONCRETE.
- THE SPALLED AND DELAMINATED EDGES SHALL BE SQUARED BY SAW-CUTTING AND CHIPPING THE CONCRETE AT THE PERIMETER BEYOND THE REMOVAL AREA AS NECESSARY TO ATTAIN A MINIMUM DEPTH OF $\frac{3}{4}$ INCH AND TO PREVENT FEATHER EDGE CONDITIONS. EXERCISE GREAT CARE TO AVOID CUTTING OR DAMAGING ANY EXISTING EMBEDDED STEEL REINFORCING. ANGLES BETWEEN ADJACENT SAW-CUTS AROUND THE PERIMETER SHALL NOT BE LESS THAN 90 DEGREES AND THE SHAPE OF EACH PATCH SHALL NOT BE IRREGULAR.
- FOR ANY EXPOSED REINFORCEMENT WITHIN THE REPAIR AREA, ADDITIONAL CONCRETE SHALL BE REMOVED FOR A MINIMUM $\frac{3}{4}$ INCH CLEAR SPACE MEASURED RADIALLY AROUND THE BARS.
- EXISTING CONCRETE SURFACES WITHIN THE REPAIR AREAS SHALL BE ROUGHENED TO ENSURE PROPER ADHESION WITH REPAIR CONCRETE.
- ALL EXPOSED CONCRETE SURFACES AND REINFORCING BARS IN THE REPAIR AREA SHALL BE NEEDLE GUNNED TO REMOVE ALL SCALE, LOOSE RUST, DEBRIS AND DETERIORATED CONCRETE.
- ANY REINFORCEMENT WHICH HAS LOST MORE THAN 20 PERCENT OF ITS CROSS-SECTIONAL AREA SHALL BE REPLACED AND CALLED TO THE ATTENTION OF THE HARBORS DIVISION CONSTRUCTION ENGINEER.
- ALL WELDING SHALL CONFORM TO AWS D1.4.
- ALL EXISTING BARS WITH CARBON EQUIVALENT (C.E.) ABOVE 0.55 PERCENT SHALL BE PREHEATED ACCORDING TO THE REQUIREMENTS SET FORTH IN AWS D.1. IF THE C.E. IS UNKNOWN, MAXIMUM PREHEAT REQUIREMENTS, FOR AN ASSUMED C.E. GREATER THAN 0.75 PERCENT SHALL BE USED.
- THE PATCH AREA SHALL BE CLEANED OF ALL DUST AND DEBRIS JUST PRIOR TO PATCHING WITH HIGH PRESSURE, OIL-FREE COMPRESSED AIR WITH APPROPRIATE PPE'S AND CONTAINMENT.

APPLICATION OF SPALL REPAIR MATERIALS:

- ALL EXPOSED STEEL IN THE REPAIR AREA SHALL BE LIBERALLY COATED WITH ANTI-CORROSION COATING PER MANUFACTURER'S RECOMMENDATIONS.
- PRIOR TO PLACEMENT OF REPAIR CONCRETE, ALL CONCRETE REPAIR SURFACES SHALL BE WASHED WITH CLEAN POTABLE WATER AND THE EXPOSED CONCRETE SURFACE SHALL BE SATURATED WITH NO WATER ACCUMULATION ON THE SURFACE.
- ALL VERTICAL AND OVERHEAD REPAIRS GREATER THAN 10 SQUARE FEET SHALL BE FORMED.
- THE CONTRACTOR SHALL NOT SECURE FORMS BY RAMSETTING. ALL HOLES AND SPALLS CAUSED BY TEMPORARY ATTACHMENTS SHALL BE PATCHED. ALL INSERTS SHALL BE REMOVED OR SHALL BE STAINLESS STEEL WITH MINIMUM $\frac{3}{4}$ INCH. COVER AFTER FORM REMOVAL.
- PATCHING COMPOUND MAY BE USED INSTEAD OF FORMED CONCRETE FOR VERTICAL AND OVERHEAD REPAIRS LESS THAN OR EQUAL TO 10 SQUARE FEET IN AREA. A SLURRY COAT OF THE COMPOUND SHALL BE USED TO PRIME THE SUBSTRATE AND THE MATERIAL SHALL BE APPLIED IN LIFTS PER MANUFACTURER'S RECOMMENDATIONS.
- SNAP TIES AND OTHER NON-REMOVABLE INSERTS SHALL BE PLASTIC OR STAINLESS STEEL.
- WITH THE EXCEPTION OF THE TOP SURFACE OF THE PIER AND OUTBOARD FACE OF EXTERIOR BEAMS, ALL FORMED CONCRETE REPAIRS SHALL BE BUILT UP TO OR BEYOND THE ORIGINAL SURFACE AND SHALL MAINTAIN A 3 INCH MINIMUM CLEAR COVER FOR REINFORCING.
- CONCRETE REPAIRS AT THE TOP SURFACE OF THE PIER AND OUTBOARD FACE OF EXTERIOR BEAMS SHALL BE BUILT UP TO THE ORIGINAL CONCRETE SURFACE.
- CONCRETE REPAIRS SHALL MATCH AND MAINTAIN EXISTING CHAMFER EDGES AND EXPANSION JOINTS. CONTRACTOR SHALL INSTALL JOINT FILLER TO MAINTAIN JOINTS.
- REPAIR CONCRETE SHALL BE VIBRATED, RODDED OR TAMPED DURING PLACEMENT TO CONSOLIDATE THE POUR AND FILL ALL CORNERS OF THE PATCH OR FORM AND BENEATH THE REINFORCING.
- THERE SHALL BE NO COLD JOINTS IN THE FIELD OF THE REPAIR.
- THE REPAIRED SURFACE FINISH SHALL MATCH THE ORIGINAL SURFACE FINISH.
- VOID SPACES BEYOND THE EDGE OF THE FORM SHALL BE DRY PACKED IN LIFTS WITH PATCHING COMPOUND.
- FORMWORK FOR CONCRETE REPAIRS ON THE PIER SUBSTRUCTURE SHALL NOT BE REMOVED FOR A MINIMUM OF 24 HOURS AND UNTIL CONCRETE HAS OBTAINED A MINIMUM COMPRESSIVE STRENGTH OF 4,000 PSI.
- CONCRETE REPAIRS ON THE UNDERSIDE OF THE PIER SHALL BE CURED EITHER BY LEAVING FORMS IN PLACE A MINIMUM OF 7 DAYS OR COVERING THE SURFACE WITH A CURING COMPOUND APPROVED BY THE HARBORS DIVISION CONSTRUCTION ENGINEER.

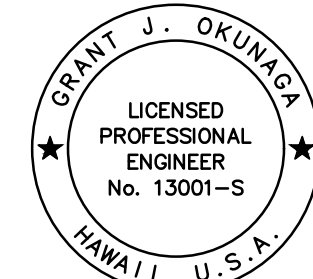
 <p>THIS WORK WAS PREPARED BY ME OR UNDER MY SUPERVISION EXP. 4-30-24 <i>Grant J. Okuniga</i> MKE ASSOCIATES LLC</p>	REVISION	DATE	DESCRIPTION	BY	APPROVED
	STATE OF HAWAII DEPARTMENT OF TRANSPORTATION HARBORS DIVISION				
	JOB TITLE FENDER REPAIRS AT PIER 1, 2 AND TUG PIER KAHULUI HARBOR, MAUI, HAWAII				
	SHEET TITLE STRUCTURAL NOTES				
DESIGNED BY: GO	DRAWN BY: DL			SHEET S-1	
CHECKED BY: GM	DATE: 04/2023			JOB NUMBER S30215	
SCALE: AS SHOWN				3 of 13 SHTS.	

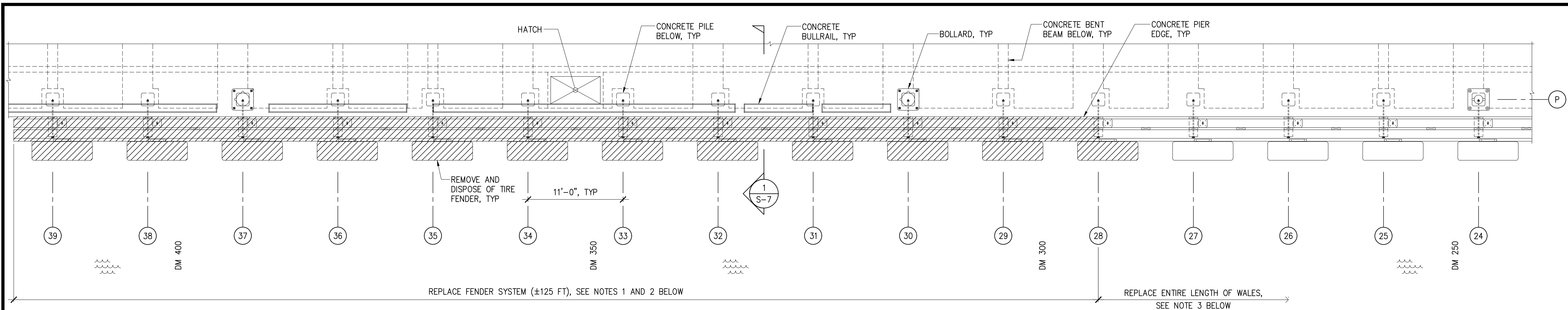

REPLACE FENDER SYSTEM (± 125 FT), SEE NOTES 1 AND 2 BELOW

REPLACE ENTIRE LENGTH OF WALES, SEE NOTE 3 BELOW

KAHULUI HARBOR

EXISTING PARTIAL PIER 1 PLAN

SCALE: 3/16" = 1'-0"

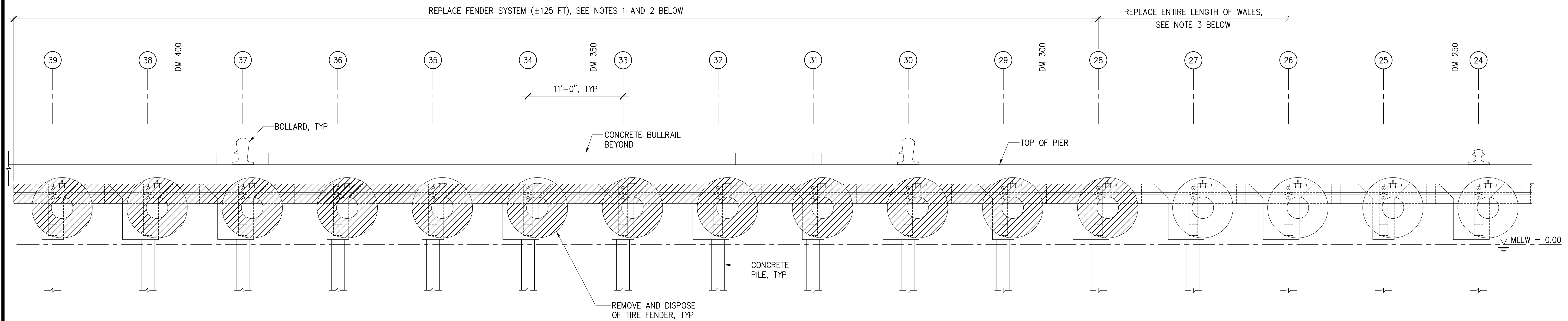

REPLACE FENDER SYSTEM (± 125 FT), SEE NOTES 1 AND 2 BELOW

REPLACE ENTIRE LENGTH OF WALES, SEE NOTE 3 BELOW

EXISTING PARTIAL PIER 1 ELEVATION

SCALE: 3/16" = 1'-0"

NOTES:

1. REMOVE AND DISPOSE OF ALL TIMBER MEMBERS INCLUDING WALES, CHAFING STRIPS, RUBBING BLOCKS AND BLOCKING.
2. REMOVE AND DISPOSE OF ALL FENDER HARDWARE INCLUDING CHAINS, SHACKLES, EYE BOLTS UNLESS NOTED OTHERWISE.
3. ENDS OF WALES ARE STAGGERED ALONG THE LENGTH OF THE PIER. REMOVE AND DISPOSE OF ENTIRE LENGTH OF WALES. DEMOLITION OF CERTAIN WALES WILL CONTINUE BEYOND BENT 28.
4. CONTRACTOR SHALL FIELD VERIFY WALE LENGTHS PRIOR TO ORDERING REPLACEMENT WALES.
5. FENDER CHAINS AND SHACKLES NOT SHOWN FOR CLARITY.

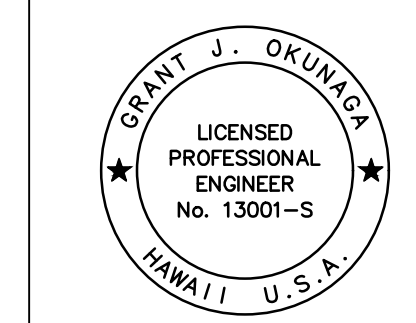

THIS WORK WAS PREPARED BY ME OR UNDER MY SUPERVISION
 EXP. 4-30-24
 MKE ASSOCIATES LLC

REVISION	DATE	DESCRIPTION	BY	APPROVED
STATE OF HAWAII DEPARTMENT OF TRANSPORTATION HARBORS DIVISION				
JOB TITLE FENDER REPAIRS AT PIER 1, 2 AND TUG PIER KAHULUI HARBOR, MAUI, HAWAII				
SHEET TITLE EXISTING PARTIAL PIER 1 PLAN AND ELEVATION				
DESIGNED BY: GO	JOB NUMBER		SHEET	
DRAWN BY: DL	S30215		S-2	
CHECKED BY: GM				
DATE: 04/2023	4 of 13 SHTS.			
SCALE: AS SHOWN				

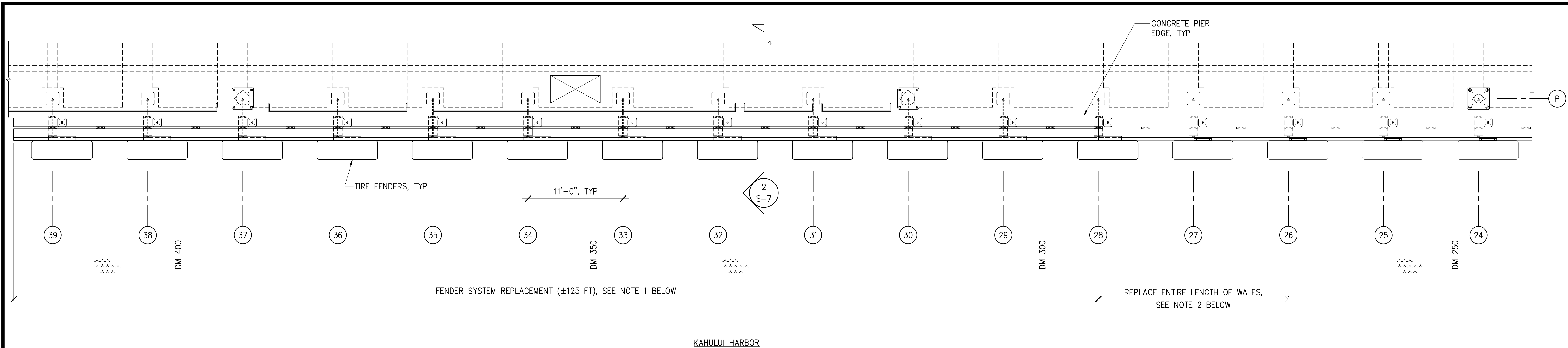

KAHULUI HARBOR

PARTIAL PIER 1 REPAIR PLAN

SCALE: 3/16" = 1'-0"

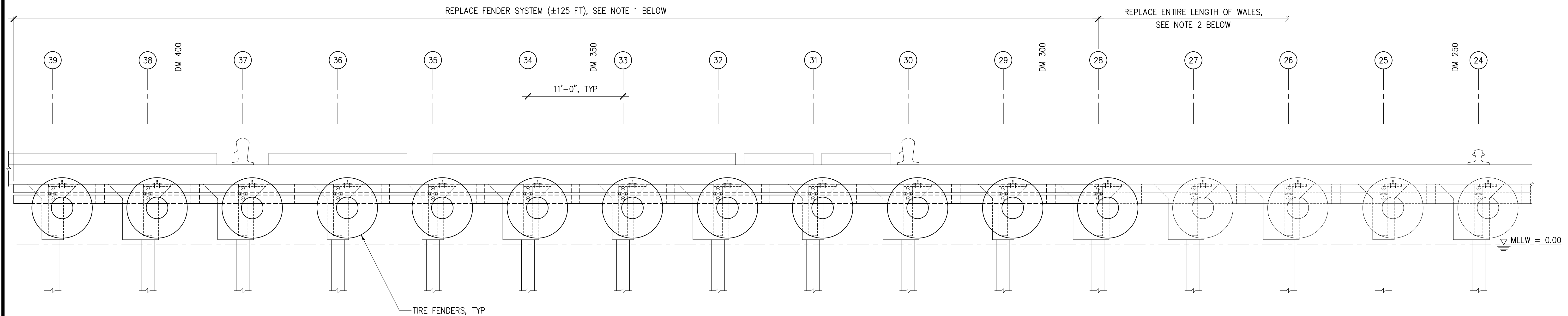

PARTIAL PIER 1 REPAIR ELEVATION

SCALE: 3/16" = 1'-0"

NOTES:

1. FENDER REPLACEMENT SHALL INCLUDE REPLACING ALL TIMBER MEMBERS AND HARDWARE. TIMBER MEMBERS INCLUDING WALES, CHAFING STRIPS, RUBBING BLOCKS AND BLOCKING. HARDWARE SHALL INCLUDE CHAINS, SHACKLES, EYE BOLTS UNLESS NOTED OTHERWISE.
2. WALES SHALL BE REPLACED ALONG THE ENTIRE LENGTH AND MAY CONTINUE BEYOND BENT 28.
3. FENDER CHAINS, GROMMETS AND SHACKLES NOT SHOWN FOR CLARITY.

		REVISION DATE DESCRIPTION BY APPROVED	
STATE OF HAWAII DEPARTMENT OF TRANSPORTATION HARBORS DIVISION			
JOB TITLE FENDER REPAIRS AT PIER 1, 2 AND TUG PIER KAHULUI HARBOR, MAUI, HAWAII			
SHEET TITLE PARTIAL PIER 1 REPAIR PLAN AND ELEVATION			
DESIGNED BY: GO	JOB NUMBER S30215	SHEET	
DRAWN BY: DL		S-3	
CHECKED BY: GM		5 of 13 SHTS.	
DATE: 04/2023			
SCALE: AS SHOWN			

THIS WORK WAS PREPARED BY ME OR UNDER MY SUPERVISION
 EXP. 4-30-24
Grant J. Okuniga
 MKE ASSOCIATES LLC

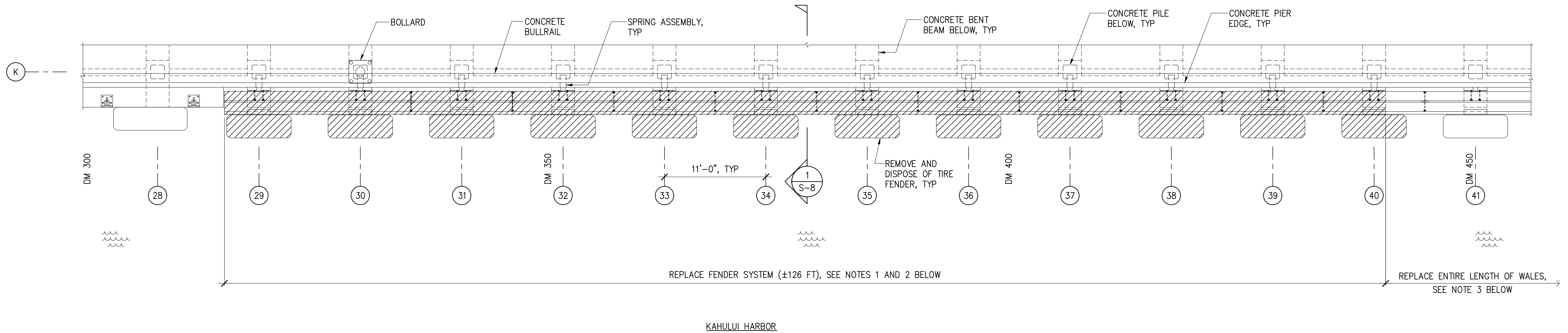

EXISTING PARTIAL PIER 2 PLAN
SCALE: 3/16" = 1'-0"

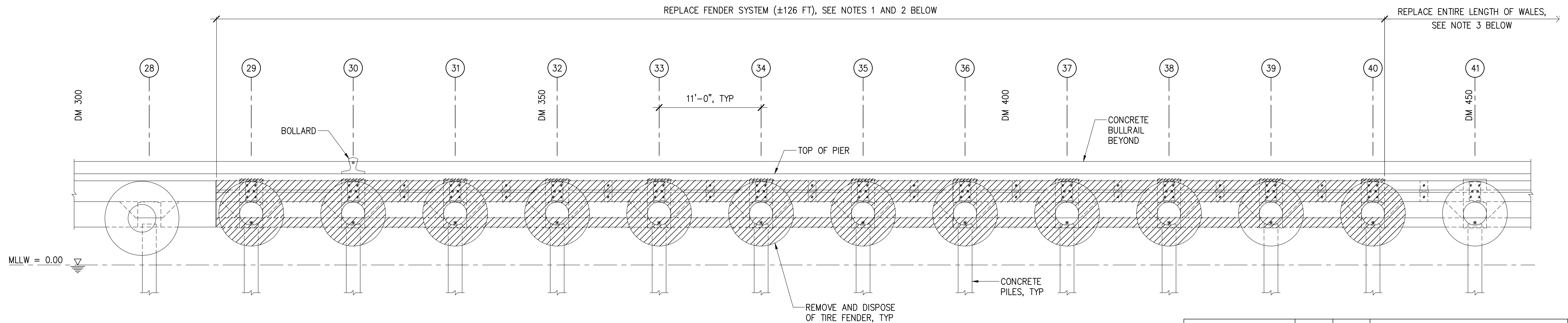

EXISTING PARTIAL PIER 2 ELEVATION
SCALE: 3/16" = 1'-0"

NOTES:

1. REMOVE AND DISPOSE OF ALL TIMBER MEMBERS INCLUDING WALES, CHAFING STRIPS, RUBBING BLOCKS AND BLOCKING.
2. REMOVE AND DISPOSE OF ALL FENDER HARDWARE INCLUDING CHAINS, SHACKLES, EYE BOLTS UNLESS NOTED OTHERWISE.
3. WALES SPLICES ARE STAGGERED ALONG THE LENGTH OF THE PIER. REMOVE AND DISPOSE OF ENTIRE LENGTH OF WALES. DEMOLITION OF CERTAIN WALES WILL CONTINUE BEYOND BENT 40.
4. CONTRACTOR SHALL FIELD VERIFY WALE LENGTHS PRIOR TO ORDERING REPLACEMENT WALES.
5. FENDER CHAINS AND SHACKLES NOT SHOWN FOR CLARITY.

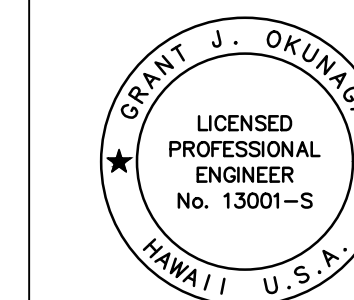

THIS WORK WAS PREPARED BY ME OR UNDER MY SUPERVISION
EXP. 4-30-24
Grant J. Okunaga
MKE ASSOCIATES LLC

REVISION	DATE	DESCRIPTION	BY	APPROVED
STATE OF HAWAII DEPARTMENT OF TRANSPORTATION HARBORS DIVISION				
JOB TITLE FENDER REPAIRS AT PIER 1, 2 AND TUG PIER KAHULUI HARBOR, MAUI, HAWAII				
SHEET TITLE EXISTING PARTIAL PIER 2 PLAN AND ELEVATION				
DESIGNED BY: GO	JOB NUMBER		SHEET	
DRAWN BY: DL	S30215		S-4	
CHECKED BY: GM	DATE: 04/2023		6 OF 13 SHEETS	
SCALE: AS SHOWN	SCALE: AS SHOWN			

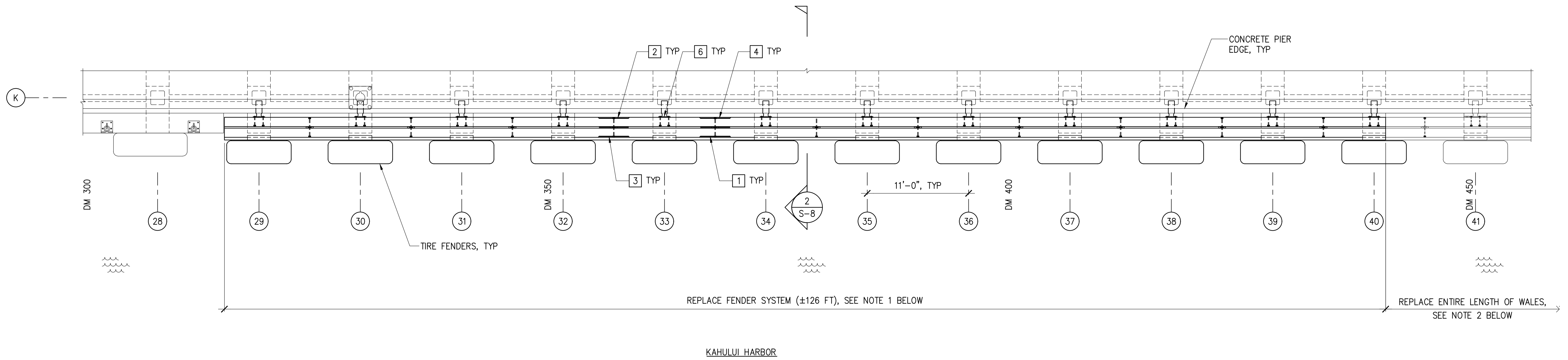

PARTIAL PIER 2 REPAIR PLAN
SCALE: 3/16" = 1'-0"

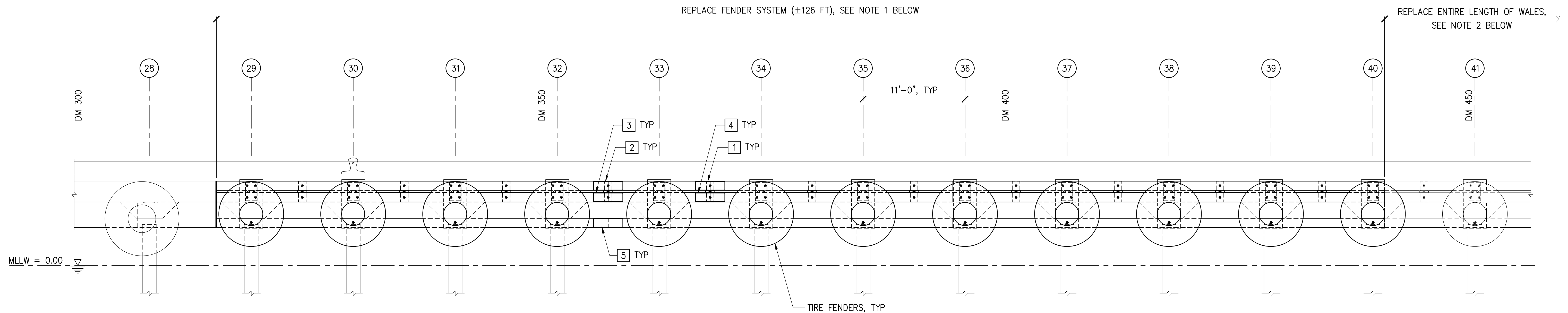

PARTIAL PIER 2 REPAIR ELEVATION
SCALE: 3/16" = 1'-0"

NOTES:

1. FENDER REPLACEMENT SHALL INCLUDE REPLACING ALL TIMBER MEMBERS AND HARDWARE. TIMBER MEMBERS INCLUDING WALES, CHAFING STRIPS, RUBBING BLOCKS AND BLOCKING. HARDWARE SHALL INCLUDE CHAINS, SHACKLES, EYE BOLTS UNLESS NOTED OTHERWISE.
2. WALES SHALL BE REPLACED ALONG THE ENTIRE LENGTH AND MAY CONTINUE BEYOND BENT 40. MINIMUM WALE LENGTH SHALL BE 22'-0".
3. TYPICAL SPLICE PLATE LOCATIONS SHOWN ONLY BETWEEN BENTS 32 TO 34 FOR CLARITY.
4. FENDER CHAINS, GROMMETS AND SHACKLES NOT SHOWN FOR CLARITY.

LEGEND:

- 1 WALE A SPLICE, SEE DETAIL 3/S-10
- 2 WALE B SPLICE, SEE DETAIL 4/S-10
- 3 WALE C SPLICE, SEE DETAIL 3/S-10
- 4 WALE D SPLICE, SEE DETAIL 4/S-10
- 5 WALE E SPLICE, SEE DETAIL 5/S-10
- 6 REPLACE PLATE AND SERVICE SPRING ASSEMBLY, SEE DETAIL 2/S-10

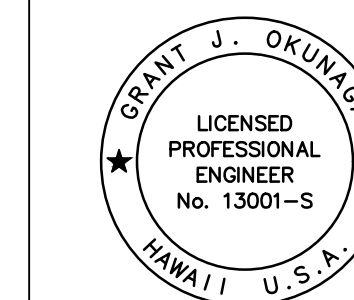

THIS WORK WAS PREPARED BY ME
OR UNDER MY SUPERVISION
EXP. 4-30-24
Grant J. Okunaga
MKE ASSOCIATES LLC

REVISION	DATE	DESCRIPTION	BY	APPROVED
STATE OF HAWAII DEPARTMENT OF TRANSPORTATION HARBORS DIVISION				
JOB TITLE FENDER REPAIRS AT PIER 1, 2 AND TUG PIER KAHULUI HARBOR, MAUI, HAWAII				
SHEET TITLE PARTIAL PIER 2 REPAIR PLAN AND ELEVATION				
DESIGNED BY: GO	JOB NUMBER		SHEET	
DRAWN BY: DL	S30215		S-5	
CHECKED BY: GM	DATE: 04/2023		7 OF 13 SHEETS	
SCALE: AS SHOWN	SCALE: AS SHOWN			

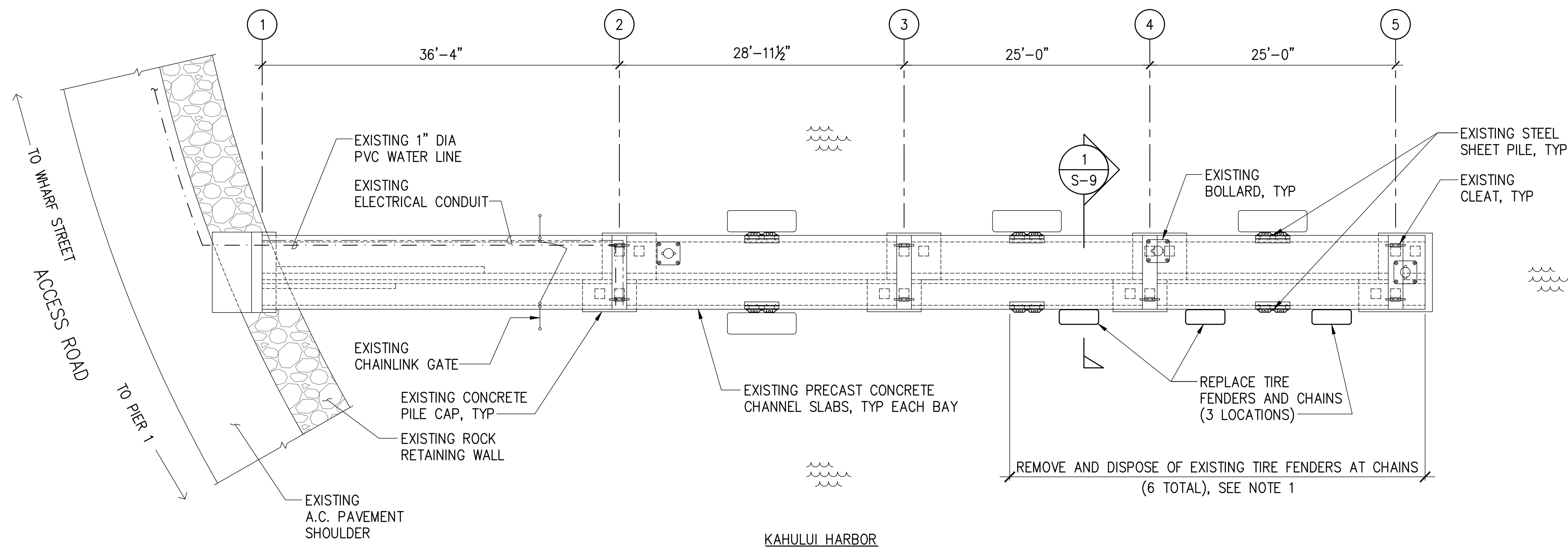

PLAN

SCALE: 1/8" = 1'-0"

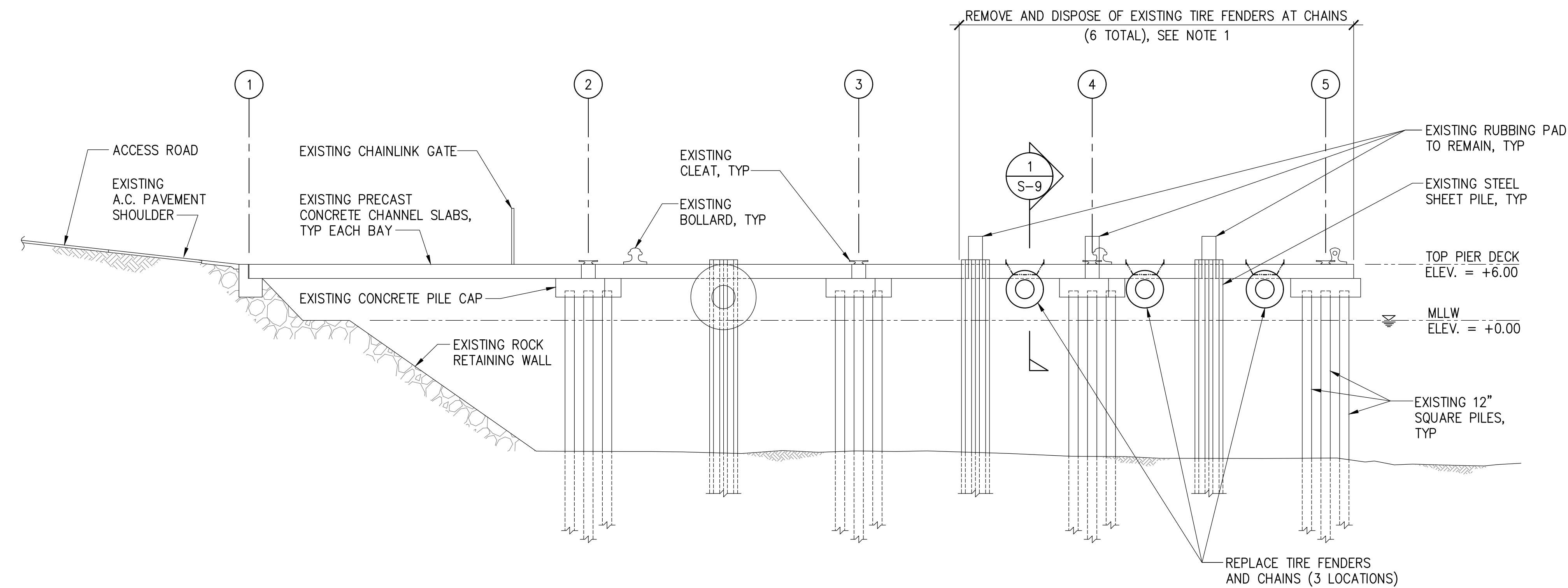

ELEVATION

SCALE: 1/8" = 1'-0"

NOTE:

- EXISTING TIRE FENDERS NOT SHOWN. SEE PHOTO IN PROJECT SPECIFICATIONS.

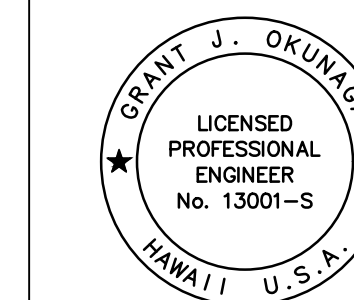

THIS WORK WAS PREPARED BY ME OR UNDER MY SUPERVISION
 EXP. 4-30-24
 MKE ASSOCIATES LLC

REVISION	DATE	DESCRIPTION	BY	APPROVED
STATE OF HAWAII DEPARTMENT OF TRANSPORTATION HARBORS DIVISION				
JOB TITLE FENDER REPAIRS AT PIER 1, 2 AND TUG PIER KAHULUI HARBOR, MAUI, HAWAII				
SHEET TITLE TUG PIER PLAN AND ELEVATION				
DESIGNED BY: GO	JOB NUMBER S30215			SHEET S-6
DRAWN BY: DL				8 of 13 SHTS.
CHECKED BY: GM				
DATE: 04/2023				
SCALE: AS SHOWN				

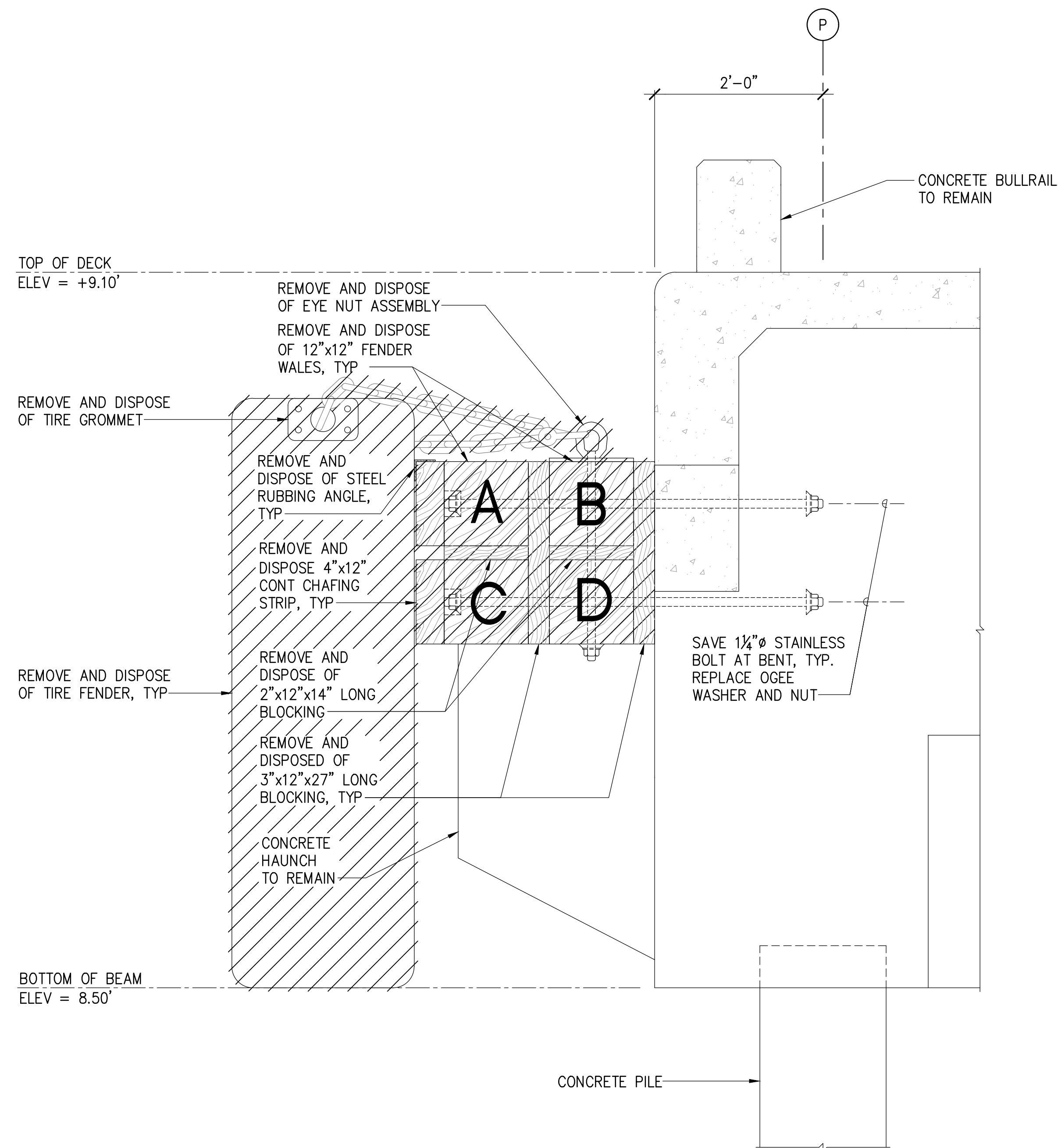

1 EXISTING SECTION AT PIER 1
SCALE: 1" = 1'-0"

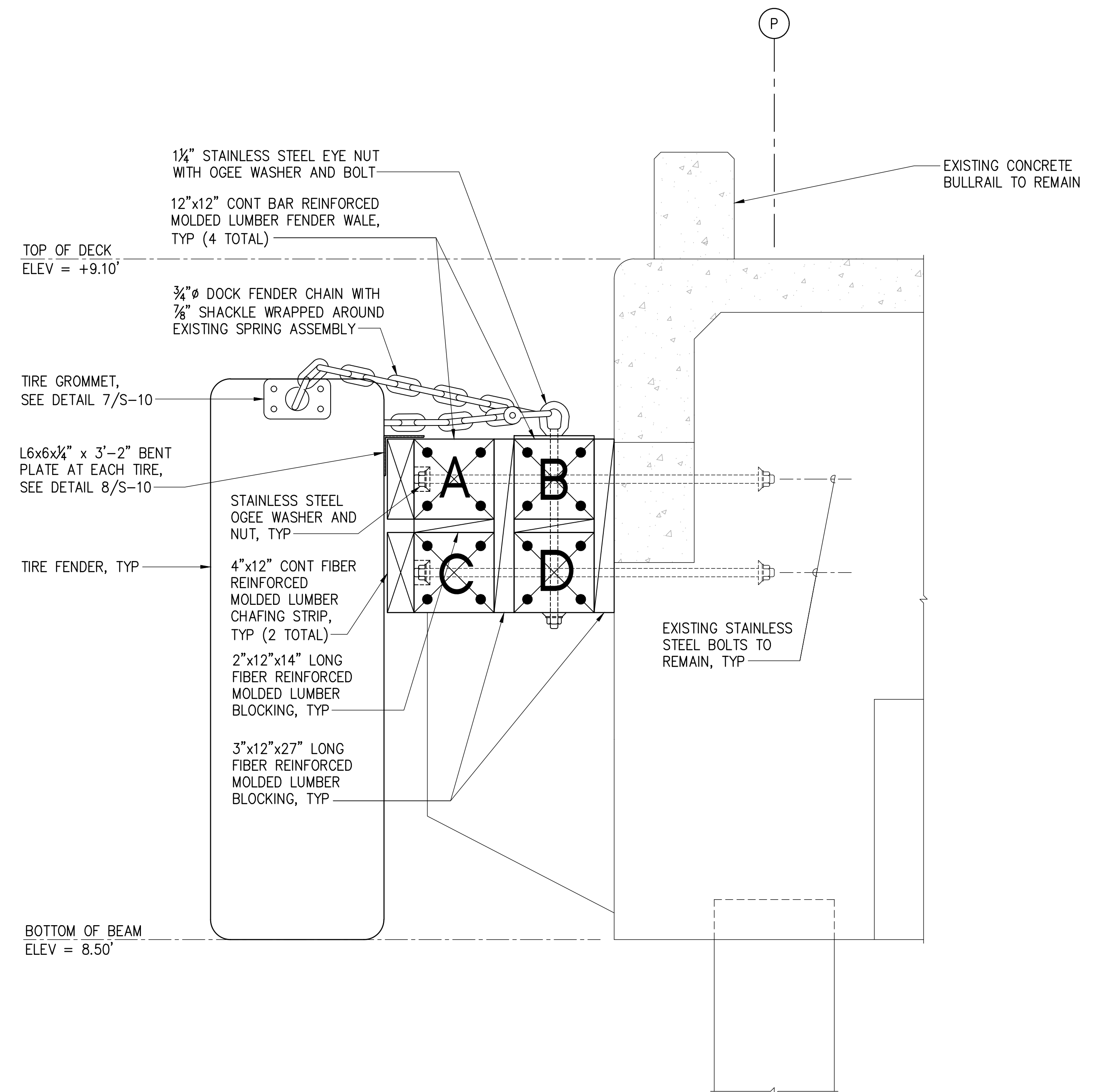

2 REPAIR SECTION AT PIER 1
SCALE: 1" = 1'-0"

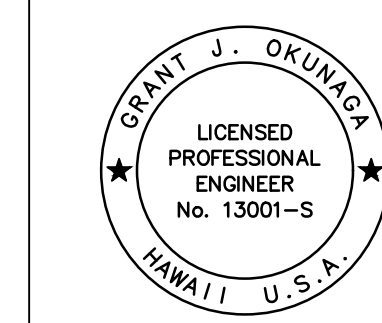

THIS WORK WAS PREPARED BY ME
OR UNDER MY SUPERVISION
EXP. 4-30-24
Grant J. Okuniga
MKE ASSOCIATES LLC

REVISION	DATE	DESCRIPTION	BY	APPROVED
STATE OF HAWAII DEPARTMENT OF TRANSPORTATION HARBORS DIVISION				
JOB TITLE FENDER REPAIRS AT PIER 1, 2 AND TUG PIER KAHULUI HARBOR, MAUI, HAWAII				
SHEET TITLE PIER 1 SECTIONS				
DESIGNED BY: GO	DRAWN BY: DL			CHECKED BY: GM
DATE: 04/2023	JOB NUMBER: S30215			SHEET: S-7
SCALE: AS SHOWN				9 of 13 SHEETS

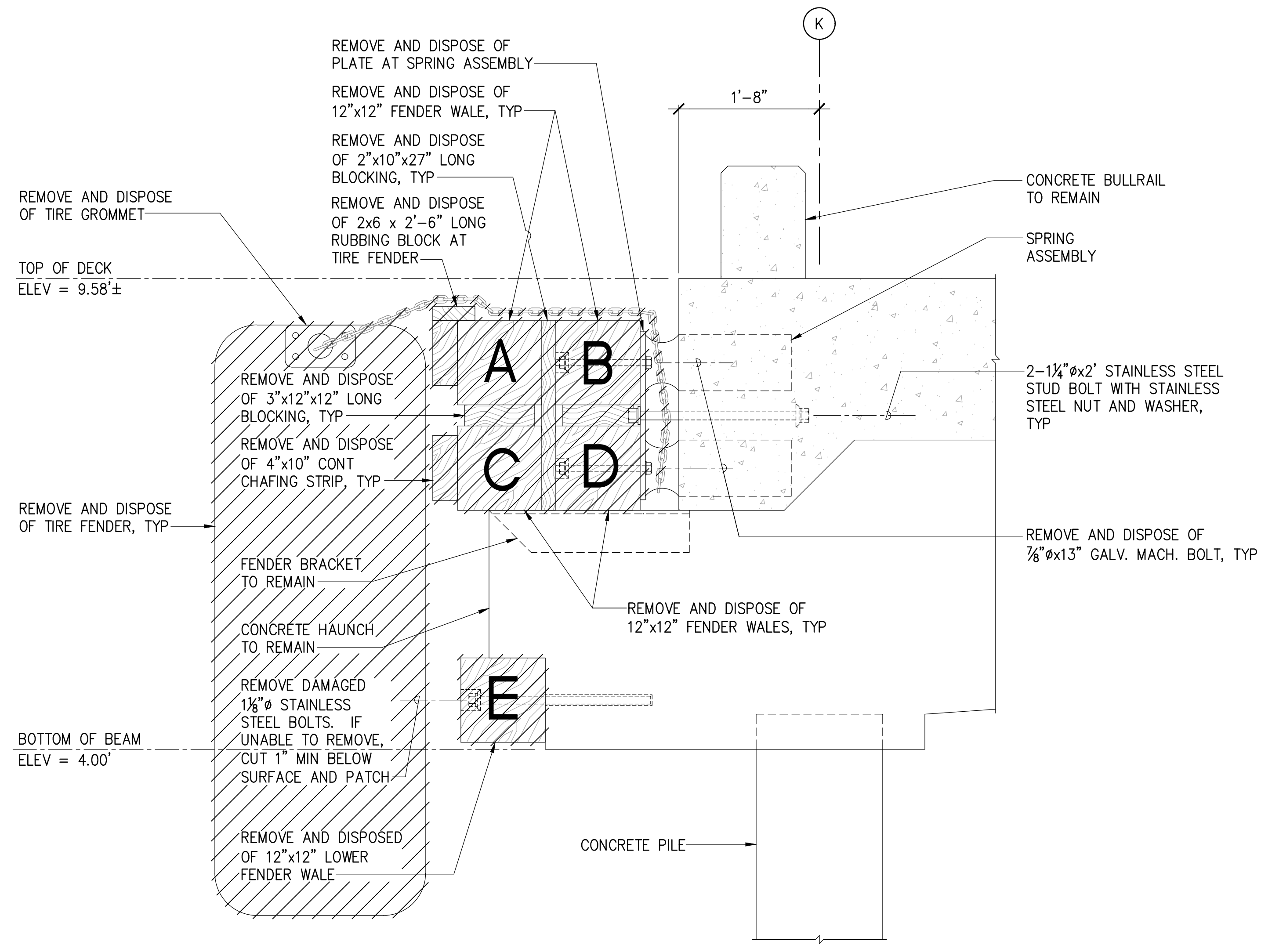

NOTE:
REMOVE WALES, CHAFING STRIPS, RUBBING BLOCKS, BLOCKING, PLATES AND MISCELLANEOUS ITEMS AS SHOWN.

1 EXISTING SECTION AT PIER 2
S-8 SCALE: 1" = 1'-0"

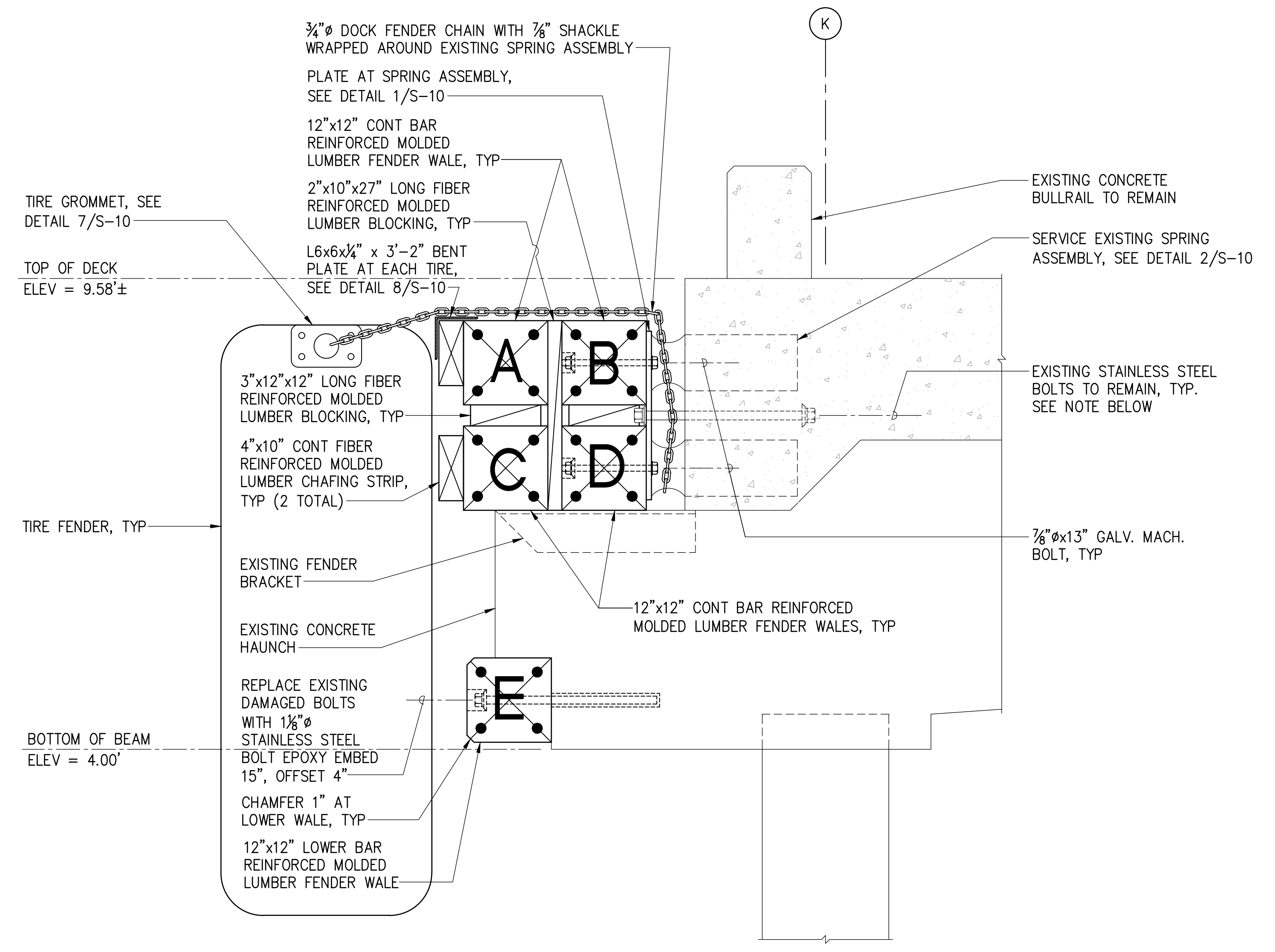

NOTE:
CONTRACTOR SHALL FIELD VERIFY 2 BOLTS ARE PRESENT.

2 REPAIR SECTION AT PIER 2
S-8 SCALE: 1" = 1'-0"

<p>THIS WORK WAS PREPARED BY ME OR UNDER MY SUPERVISION EXP. 4-30-24 <i>Grant J. Okuniga</i> MKE ASSOCIATES LLC</p>	REVISION	DATE	DESCRIPTION	BY	APPROVED
	STATE OF HAWAII DEPARTMENT OF TRANSPORTATION HARBORS DIVISION				
	JOB TITLE FENDER REPAIRS AT PIER 1, 2 AND TUG PIER KAHULUI HARBOR, MAUI, HAWAII				
	SHEET TITLE PIER 2 SECTIONS				
DESIGNED BY: GO	JOB NUMBER			SHEET	
DRAWN BY: DL	S30215			S-8	
CHECKED BY: GM					
DATE: 04/2023					
SCALE: AS SHOWN				10 of 13 SHTS.	

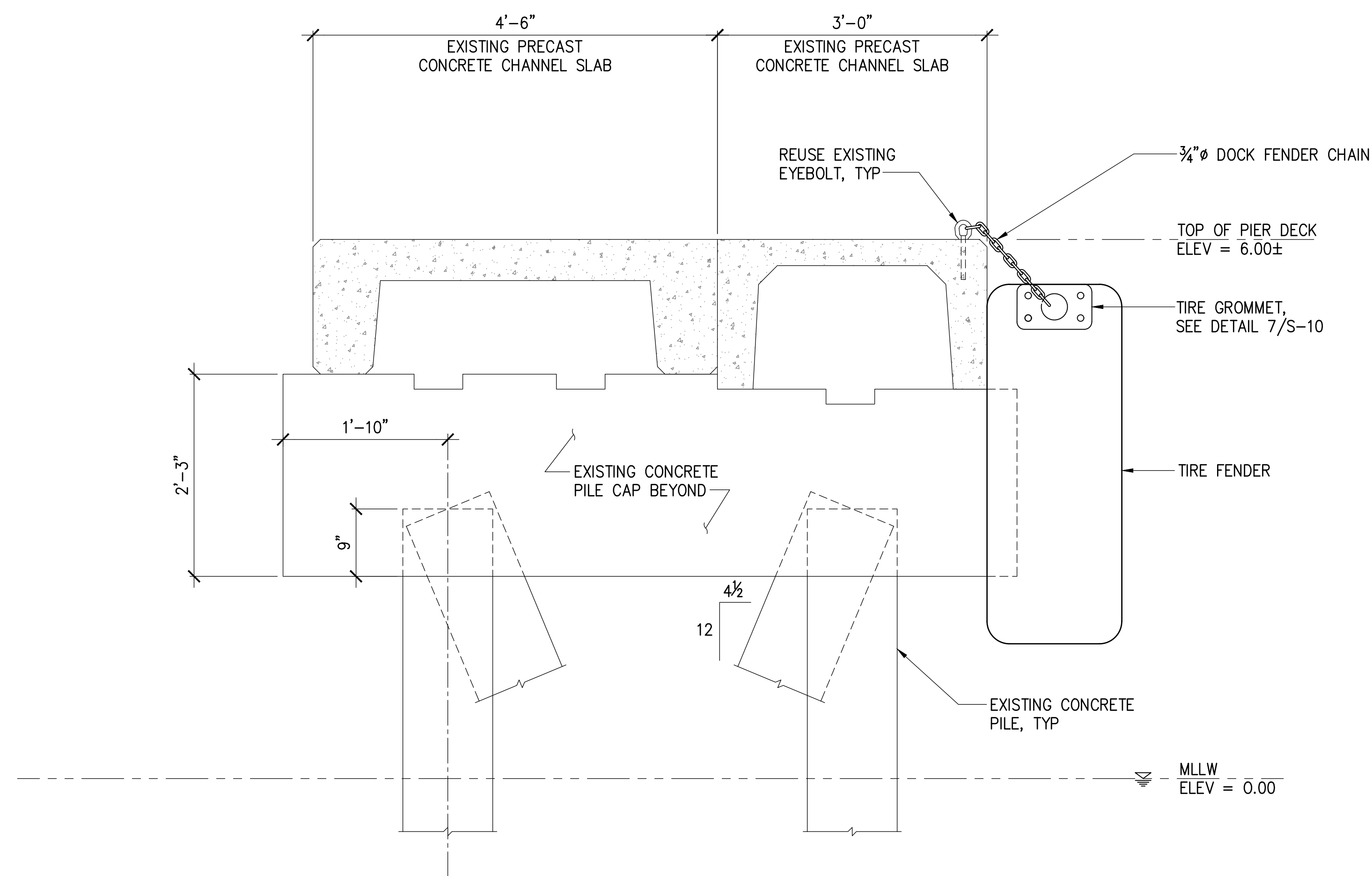

1 EXISTING SECTION AT TUG PIER
 S-9 SCALE: 1" = 1'-0"

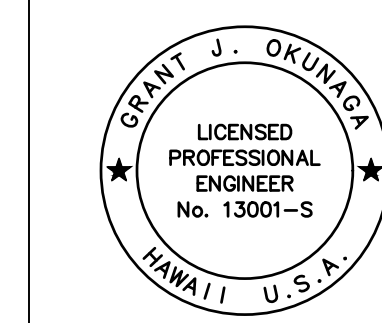

THIS WORK WAS PREPARED BY ME
 OR UNDER MY SUPERVISION
 EXP. 4-30-24
 MKE ASSOCIATES LLC

REVISION	DATE	DESCRIPTION	BY	APPROVED
STATE OF HAWAII DEPARTMENT OF TRANSPORTATION HARBORS DIVISION				
JOB TITLE FENDER REPAIRS AT PIER 1, 2 AND TUG PIER KAHULUI HARBOR, MAUI, HAWAII				
SHEET TITLE TUG PIER SECTION				
DESIGNED BY: GO	JOB NUMBER S30215			SHEET S-9
DRAWN BY: DL				11 of 13 SHEETS
CHECKED BY: GM				
DATE: 04/2023 SCALE: AS SHOWN				

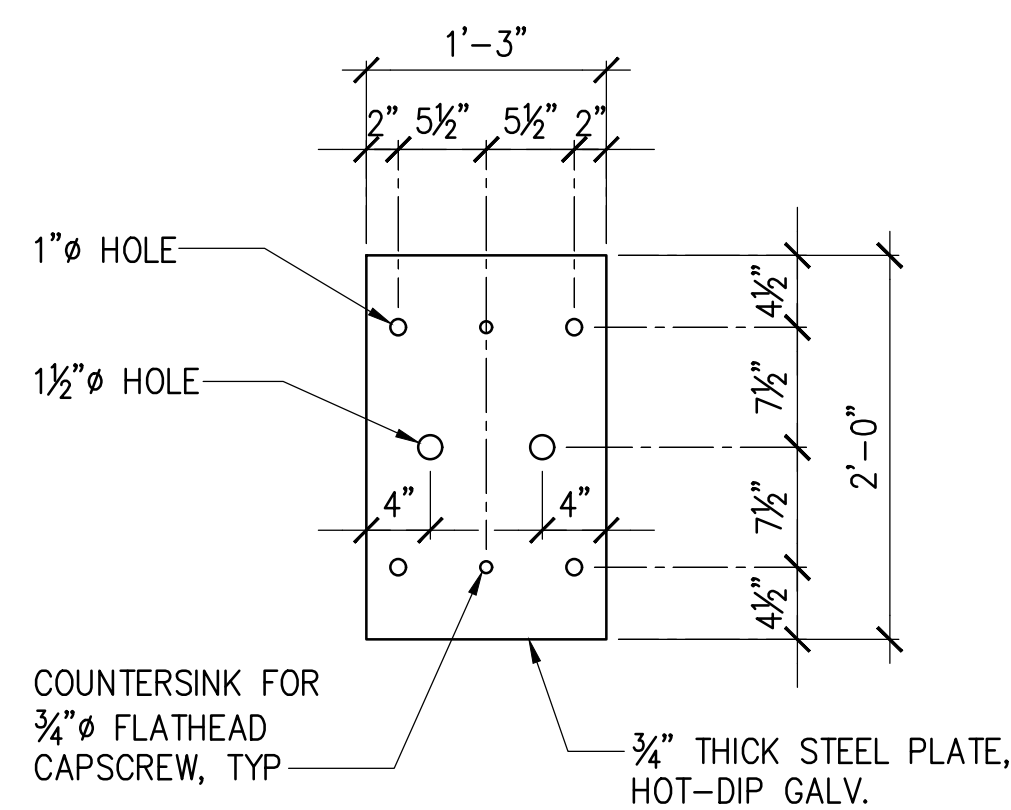

NOTES:

- 1 STEEL PLATE DETAIL
S-10 SCALE: 1" = 1'-0"
- FIELD VERIFY LOCATION AND SPACING PRIOR TO PLATE FABRICATION.
 - REPLACE ALL BOLTS CONNECTED TO WALERS.

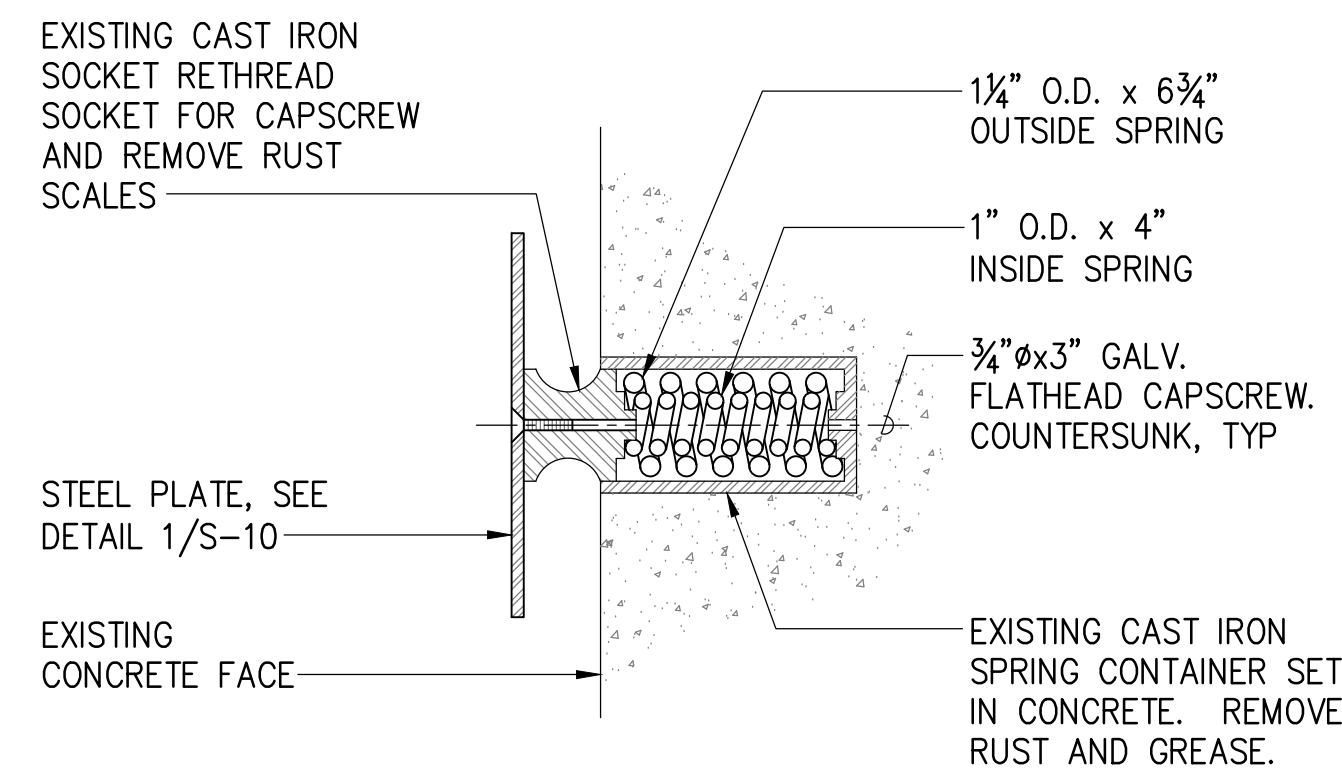

- 2 SPRING ASSEMBLY DETAIL
S-10 SCALE: 1" = 1'-0"

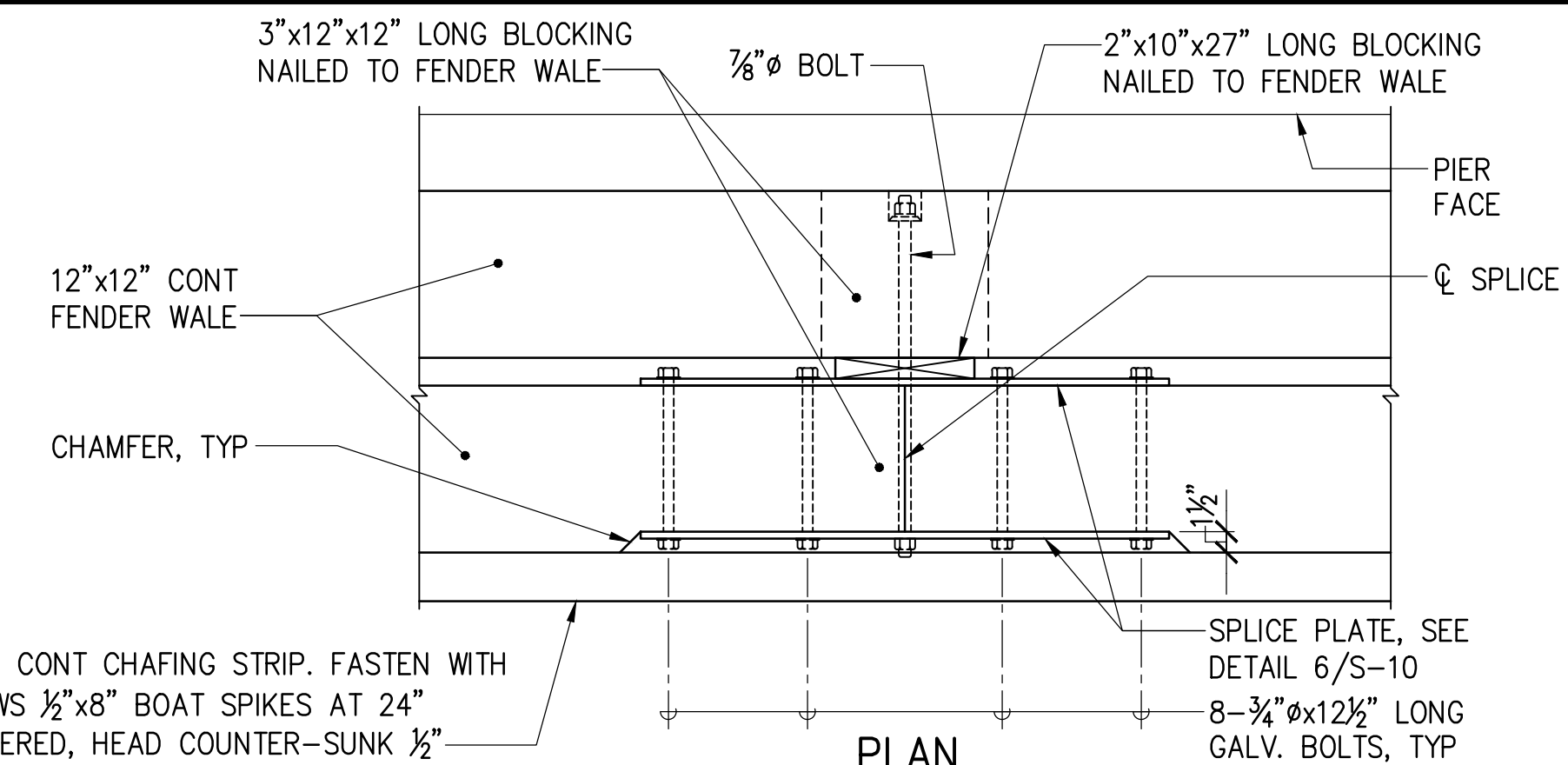

- 3 WALER A AND C SPLICE DETAIL
S-10 SCALE: 1" = 1'-0"

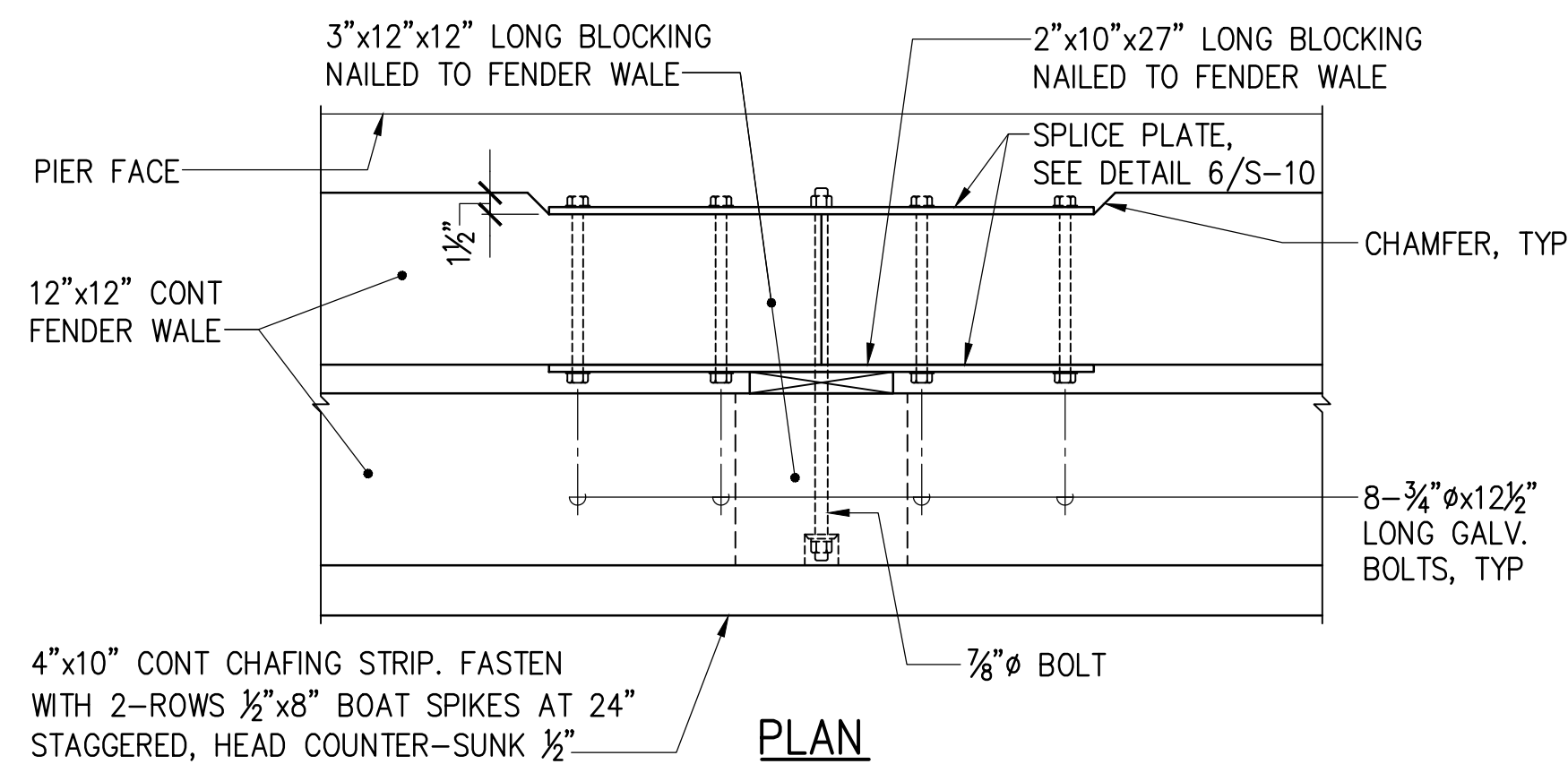

- 4 WALER B AND D SPLICE DETAIL
S-10 SCALE: 1" = 1'-0"

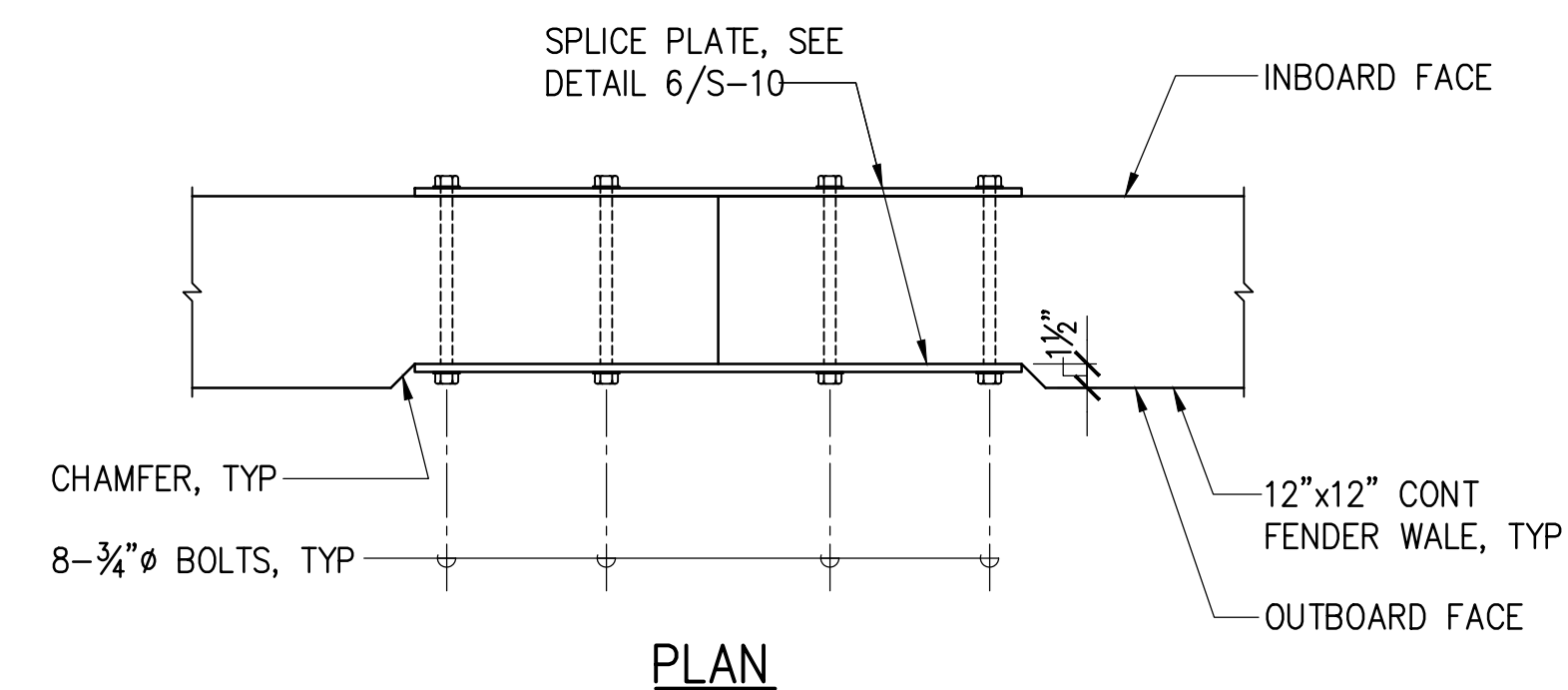

- 5 WALER E SPLICE DETAIL
S-10 SCALE: 1" = 1'-0"

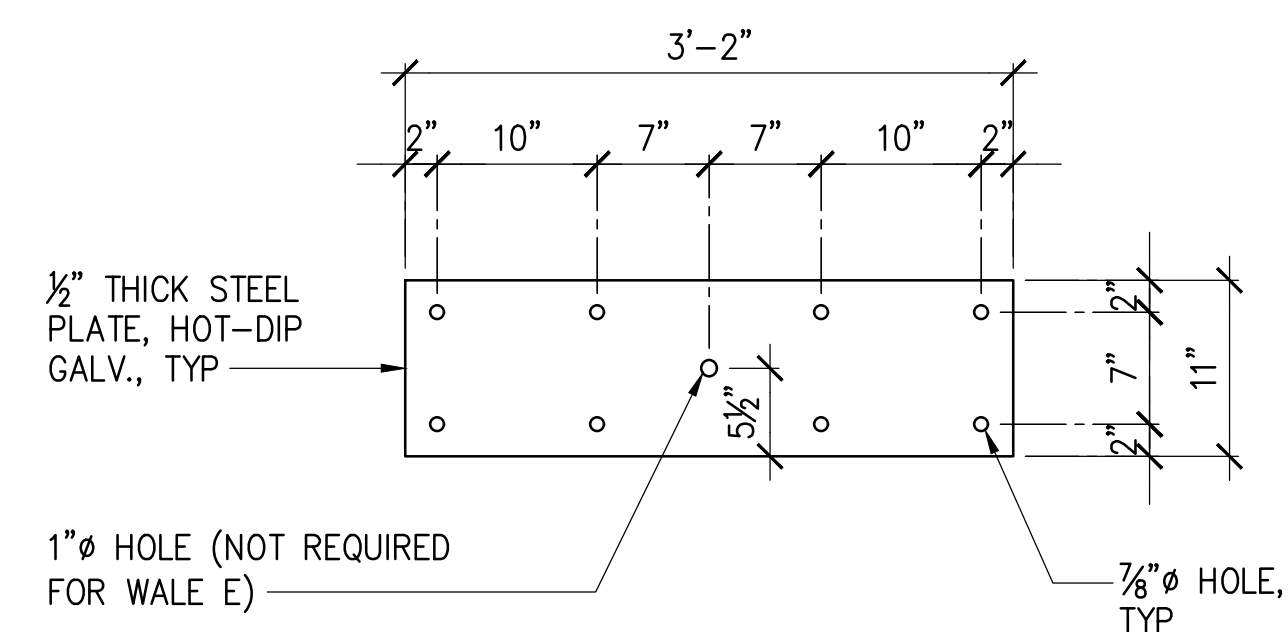

- 6 SPLICE PLATE DETAIL
S-10 SCALE: 1" = 1'-0"

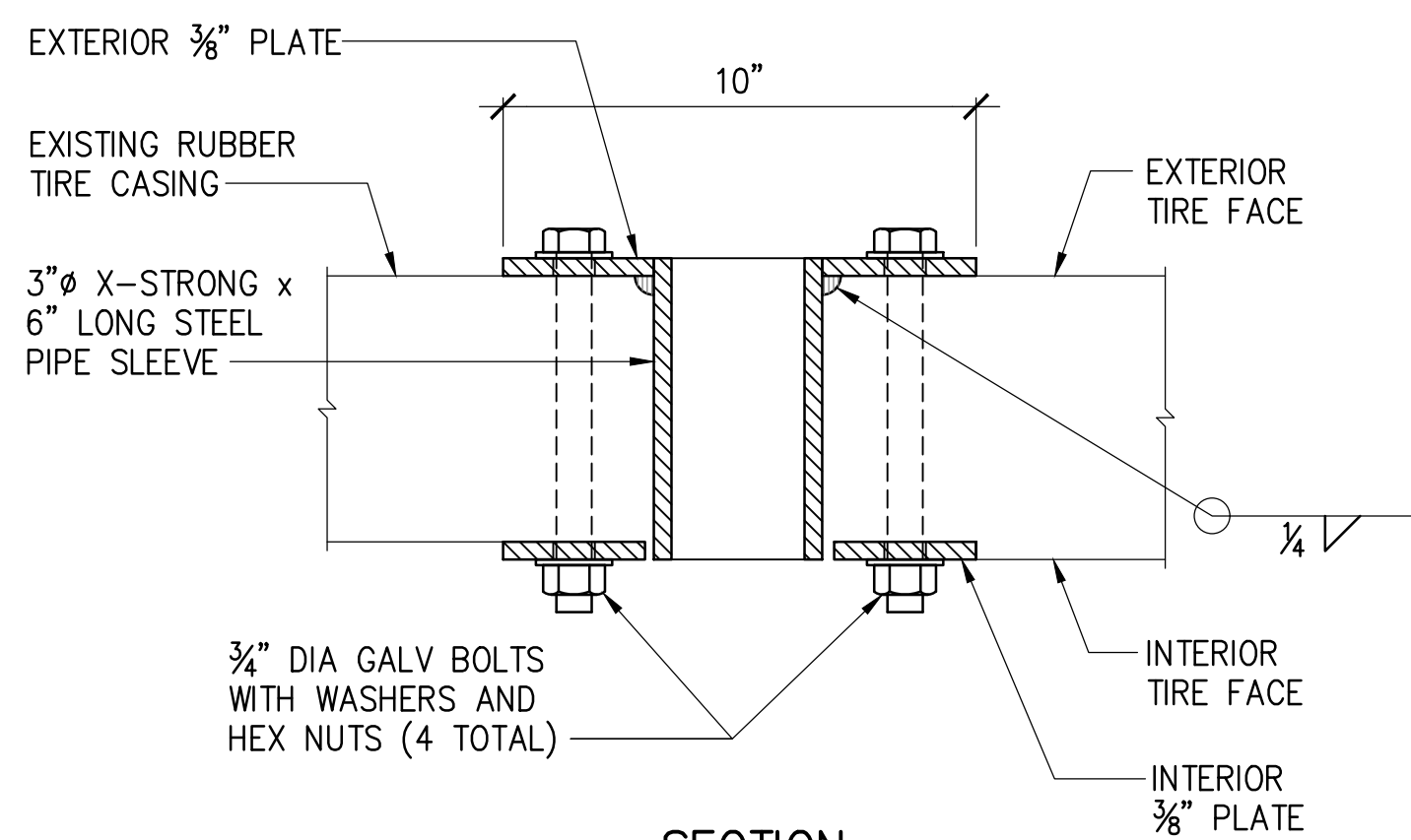
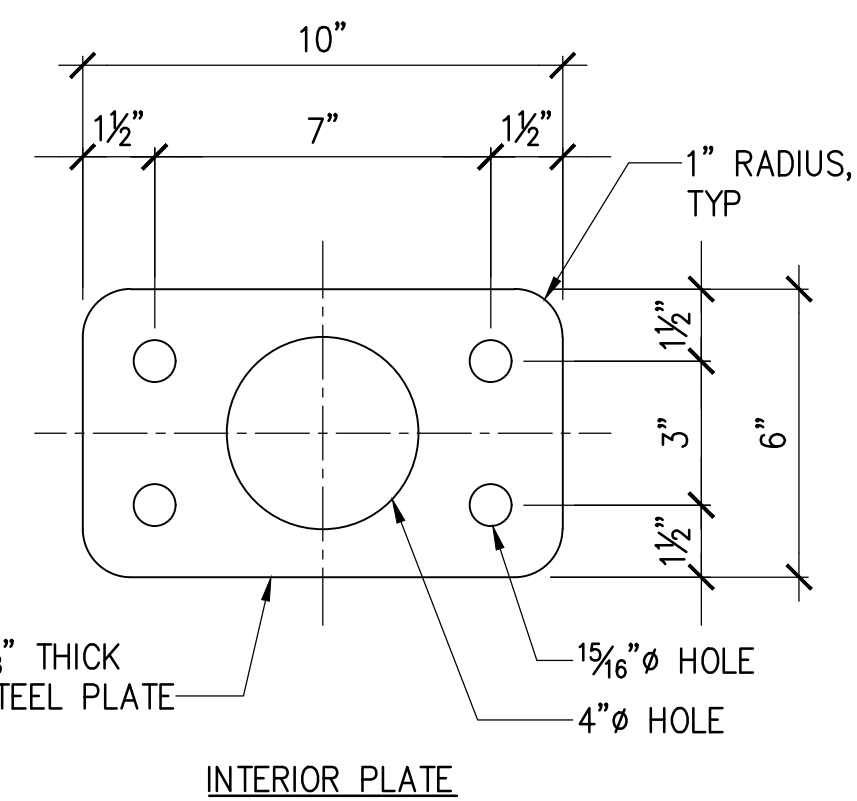
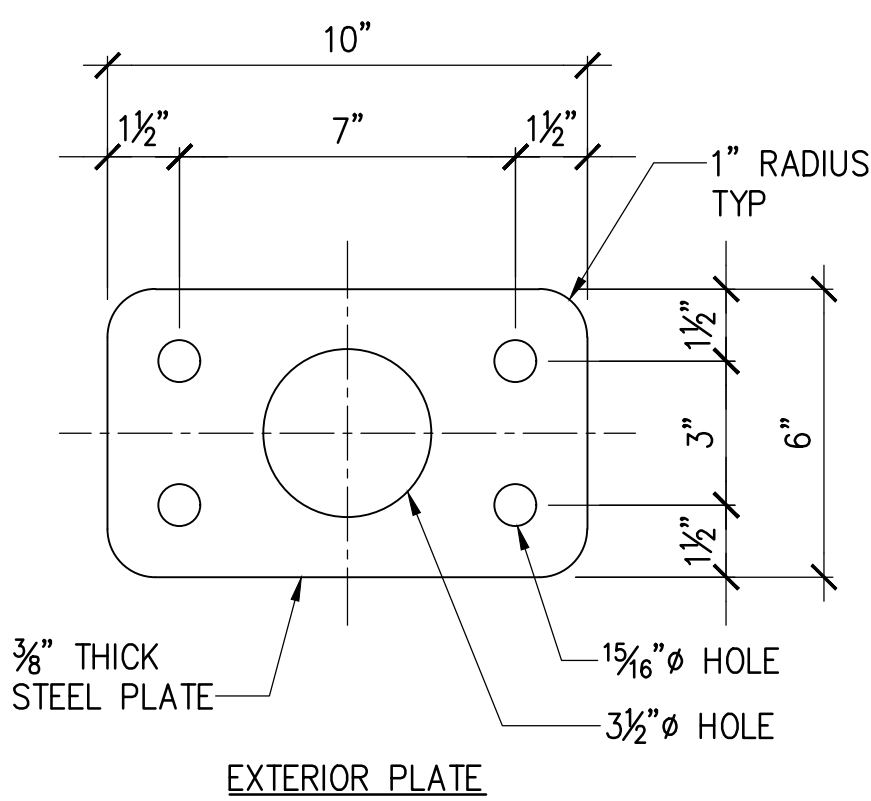

- 7 TIRE GROMMET DETAIL
S-10 SCALE: 3" = 1'-0"

- NOTES:
- TIRE GROMMETS SHALL BE HOT DIPPED GALVANIZED AFTER FABRICATION.
 - ROTATE TIRE AND INSTALL TIRE GROMMETS INTO UNDAMAGED AREA OF RUBBER TIRE CASING.

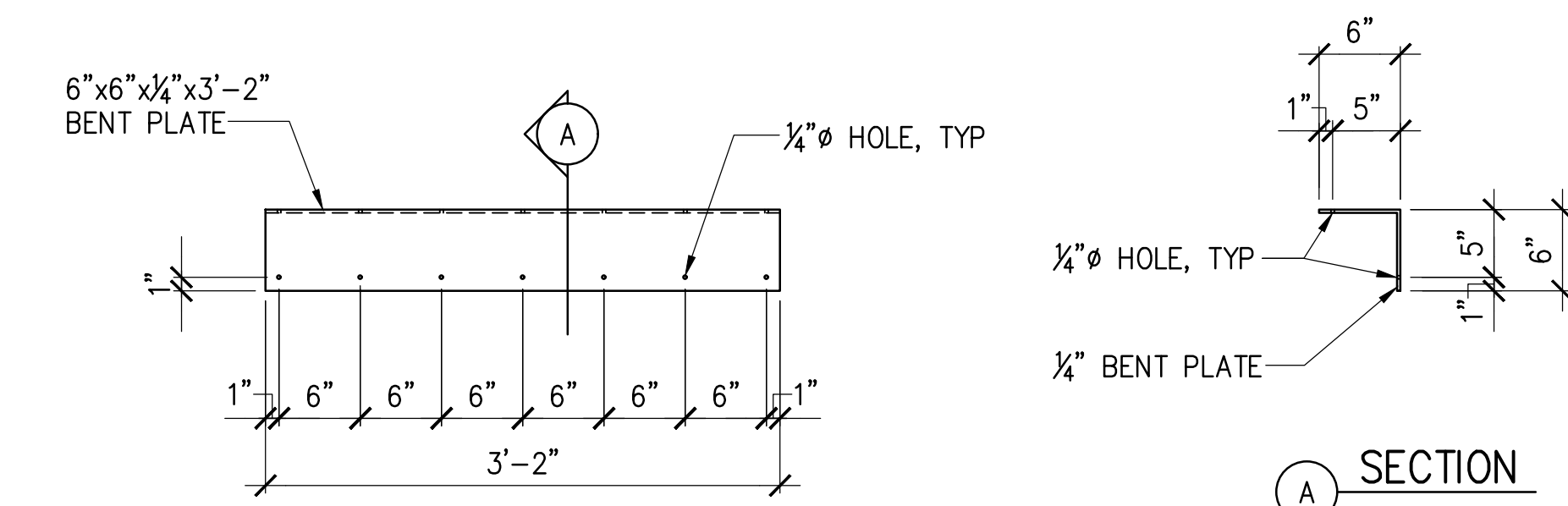

- 8 BENT PLATE DETAIL
S-10 SCALE: 1" = 1'-0"

- NOTE:
SECURE WITH 3/16" x 4" STAINLESS STEEL SCREWS.

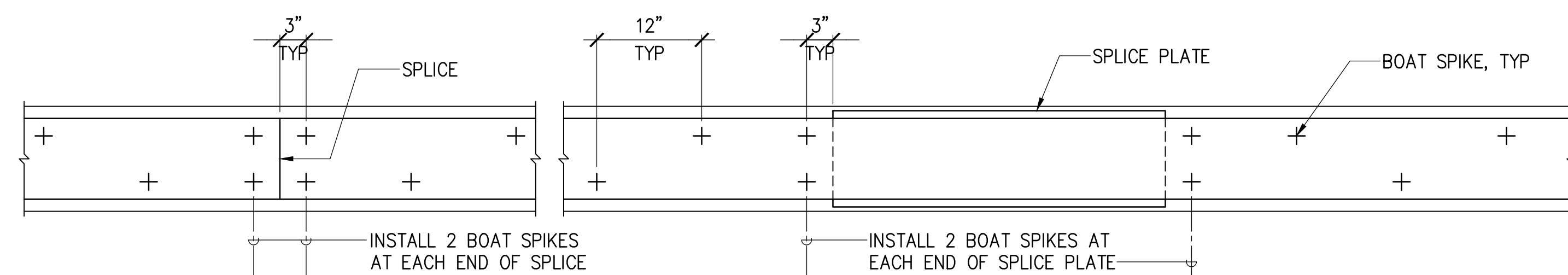

- 9 CHAFING STRIP NAILING
S-10 SCALE: 1" = 1'-0"

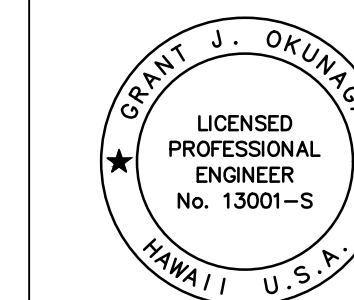

THIS WORK WAS PREPARED BY ME OR UNDER MY SUPERVISION
EXP. 4-30-24
MKE ASSOCIATES LLC

REVISION	DATE	DESCRIPTION	BY	APPROVED
STATE OF HAWAII DEPARTMENT OF TRANSPORTATION HARBORS DIVISION				
JOB TITLE FENDER REPAIRS AT PIER 1, 2 AND TUG PIER KAHULUI HARBOR, MAUI, HAWAII				
SHEET TITLE FENDER DETAILS				
DESIGNED BY: GO	JOB NUMBER S30215		SHEET S-10	
DRAWN BY: DL			12 of 13 SHTS.	
CHECKED BY: GM				
DATE: 04/2023				
SCALE: AS SHOWN				

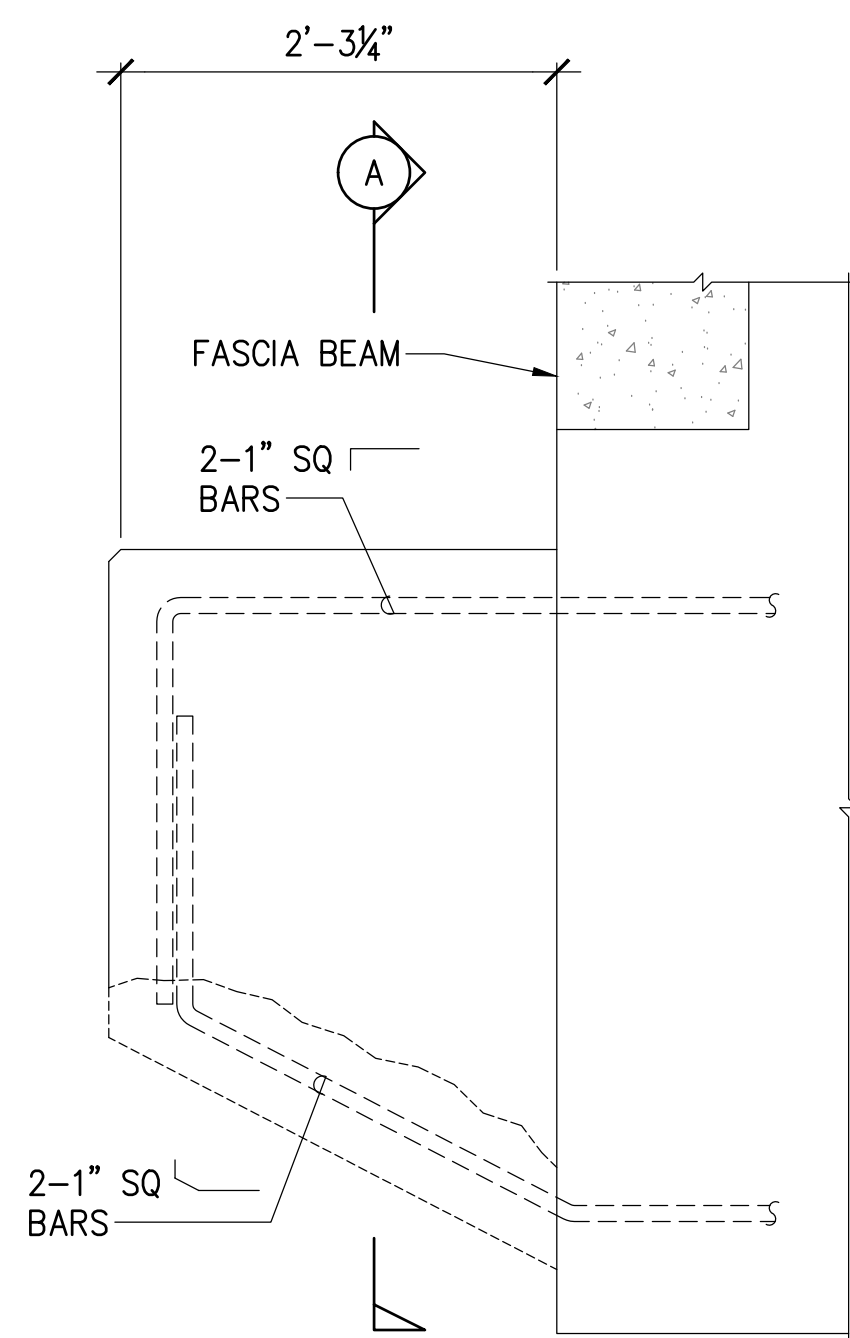

NOTE:
ADDITIONAL REINFORCING STEEL FROM PREVIOUS REPAIRS NOT SHOWN AND MAY BE PRESENT.

SIDE ELEVATION

A SECTION

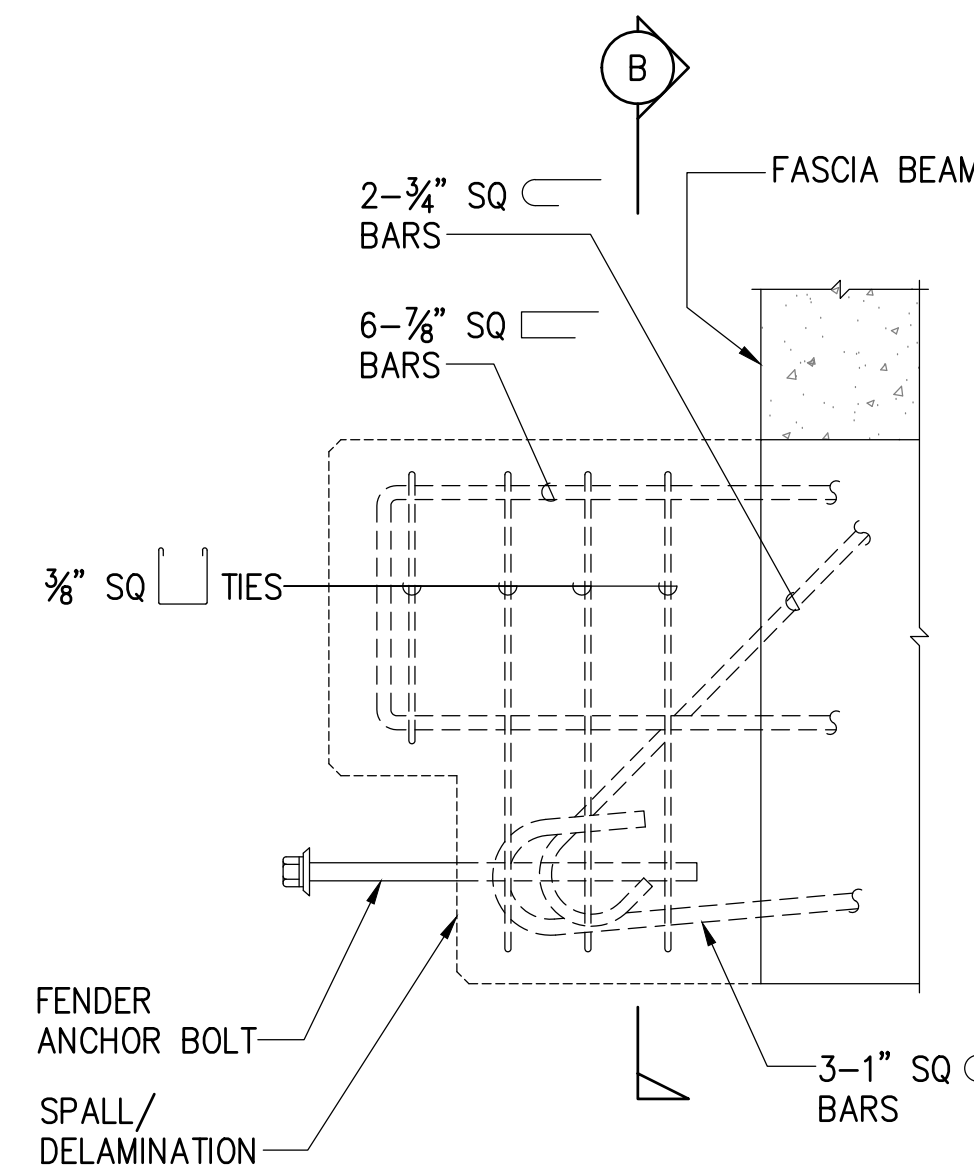

SIDE ELEVATION

B SECTION

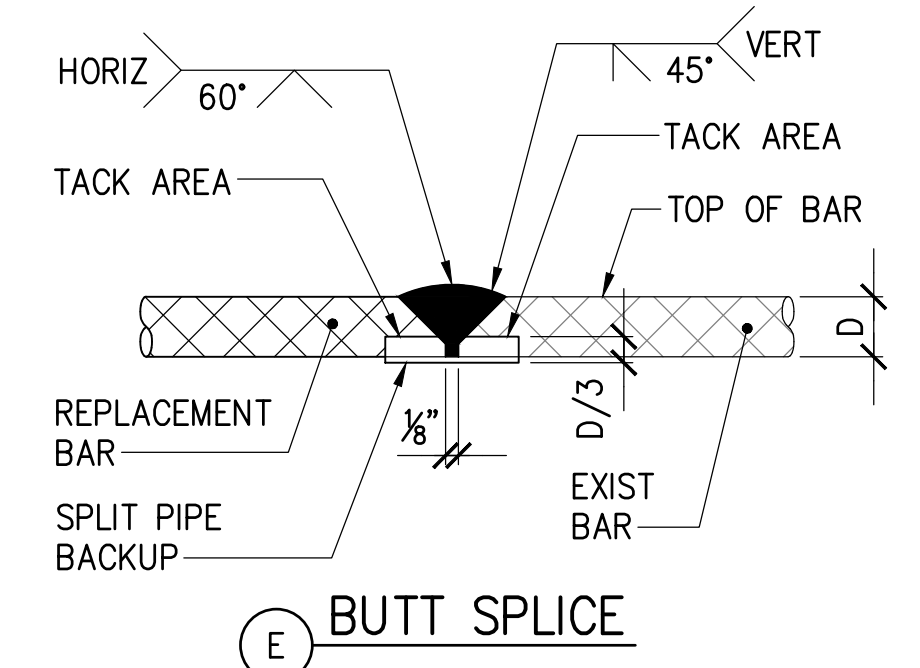

USE DETAIL E FOR #7 BARS AND LARGER

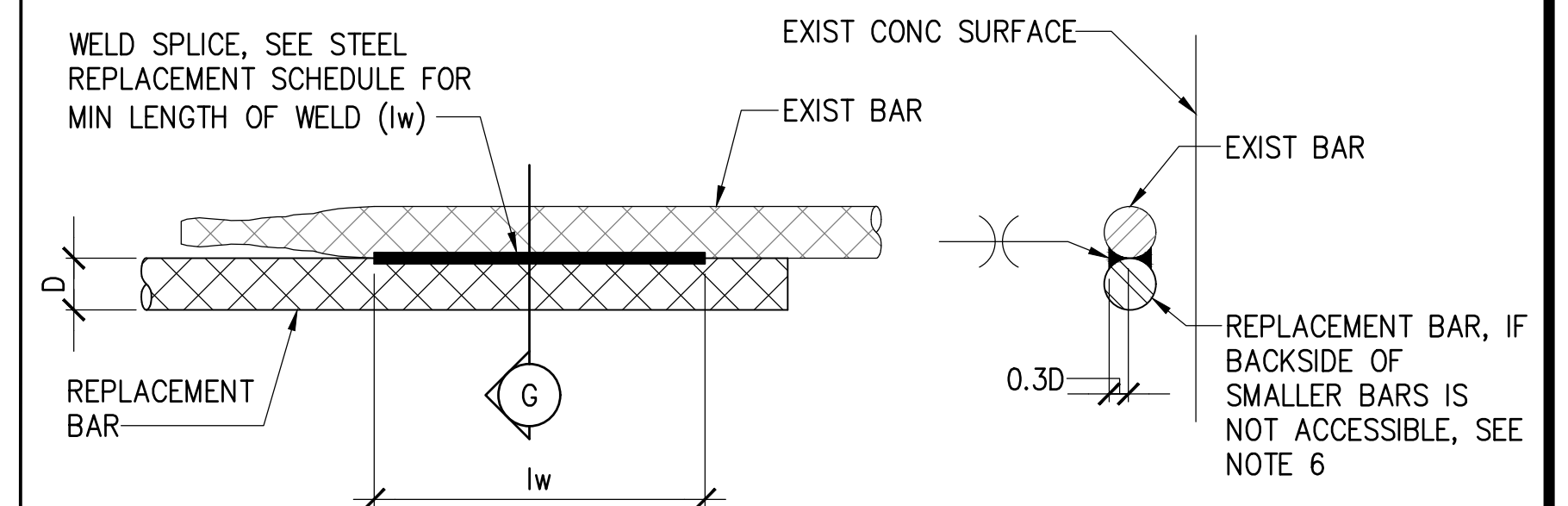

NOTE:
lw = LENGTH OF WELD EACH SIDE
(SEE STEEL REPLACEMENT SCHEDULE)

F LAP SPlice

G SECTION

USE DETAIL F FOR #6 BARS AND SMALLER

REINFORCING STEEL WELDING NOTES:

1. CHIP, GRIND, OR GOUGE TO SOUND METAL BEFORE WELDING.
2. CLEAN EXIST REBAR AND PREPARE ACCORDING TO SPECIFICATIONS. APPLY COATING AFTER WELDING.
3. SEE STEEL REPLACEMENT SCHEDULE BELOW FOR REPLACEMENT BAR SIZE.
4. USE E70 ELECTRODES.
5. SEE AWS D1.4 FOR WELDING PROCESS AND OTHER DETAILS.
6. FOR WELDING OF #3, #4, AND #5 REPLACEMENT REINFORCING, WELDING MAY BE PERFORMED ON ONE SIDE ONLY, IF lw IS INCREASED TO lw1 AS FOLLOWS

STEEL REPLACEMENT SCHEDULE				
SIZE OF EXISTING REINFORCING		SIZE OF REPLACEMENT REINFORCING	MINIMUM LENGTH OF WELD EACH SIDE (lw)	MINIMUM LENGTH OF WELD ONE SIDE lw1
SQUARE	ROUND			
3/8"	#3, #4	#4	2"	4"
1/2"	#5	#5	2 1/2"	5"
5/8"	#6	#6	3 1/2"	-
3/4"	#7	#7	-	-
7/8"	#8	#8	-	-

2 REINFORCING STEEL SPLICE DETAIL
S-11 NOT TO SCALE

PARTIAL HAUNCH SPALL REPAIR
(CONDITION AT PIER 1 SHOWN)

EXISTING CONDITION

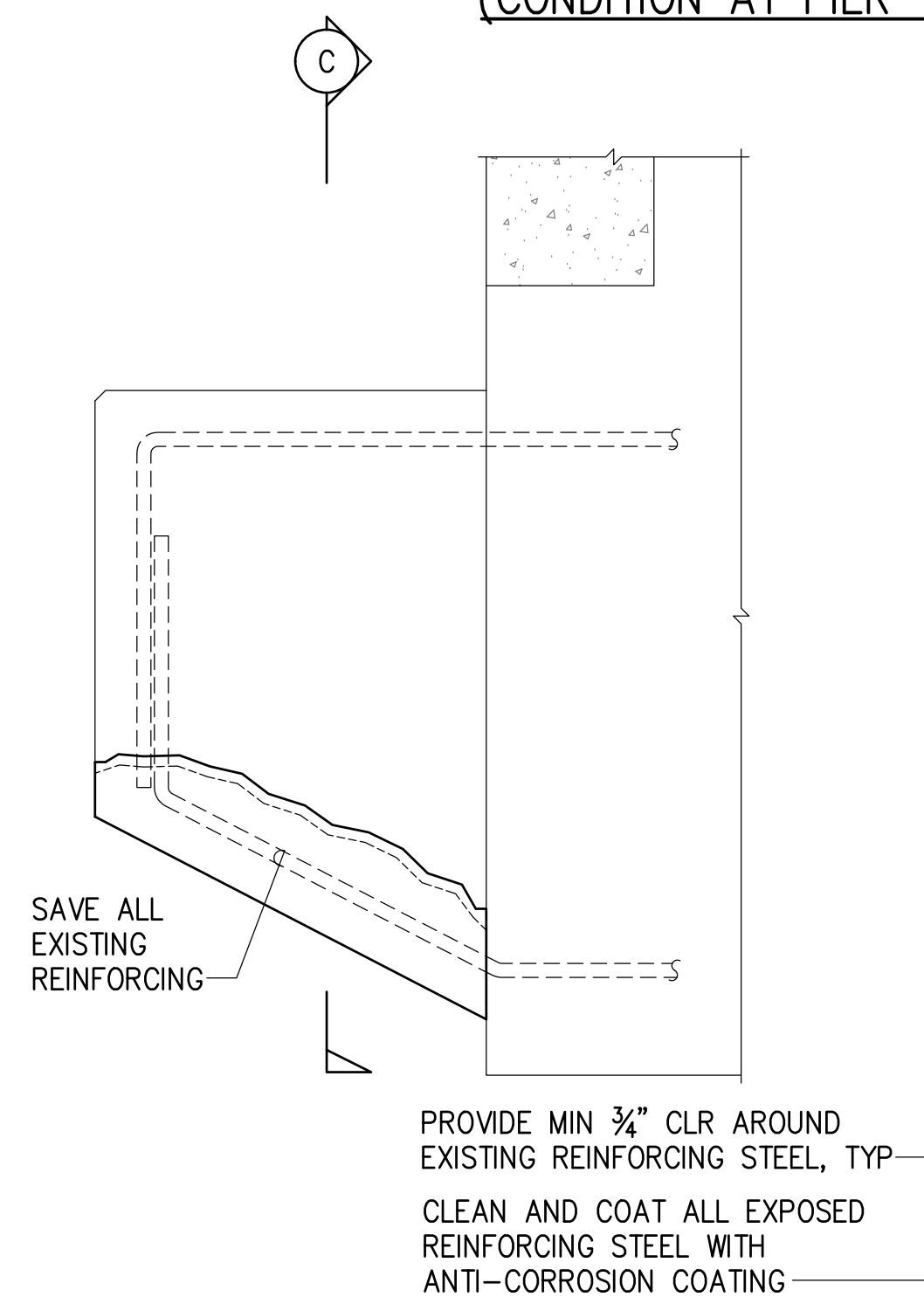

SIDE ELEVATION

C SECTION

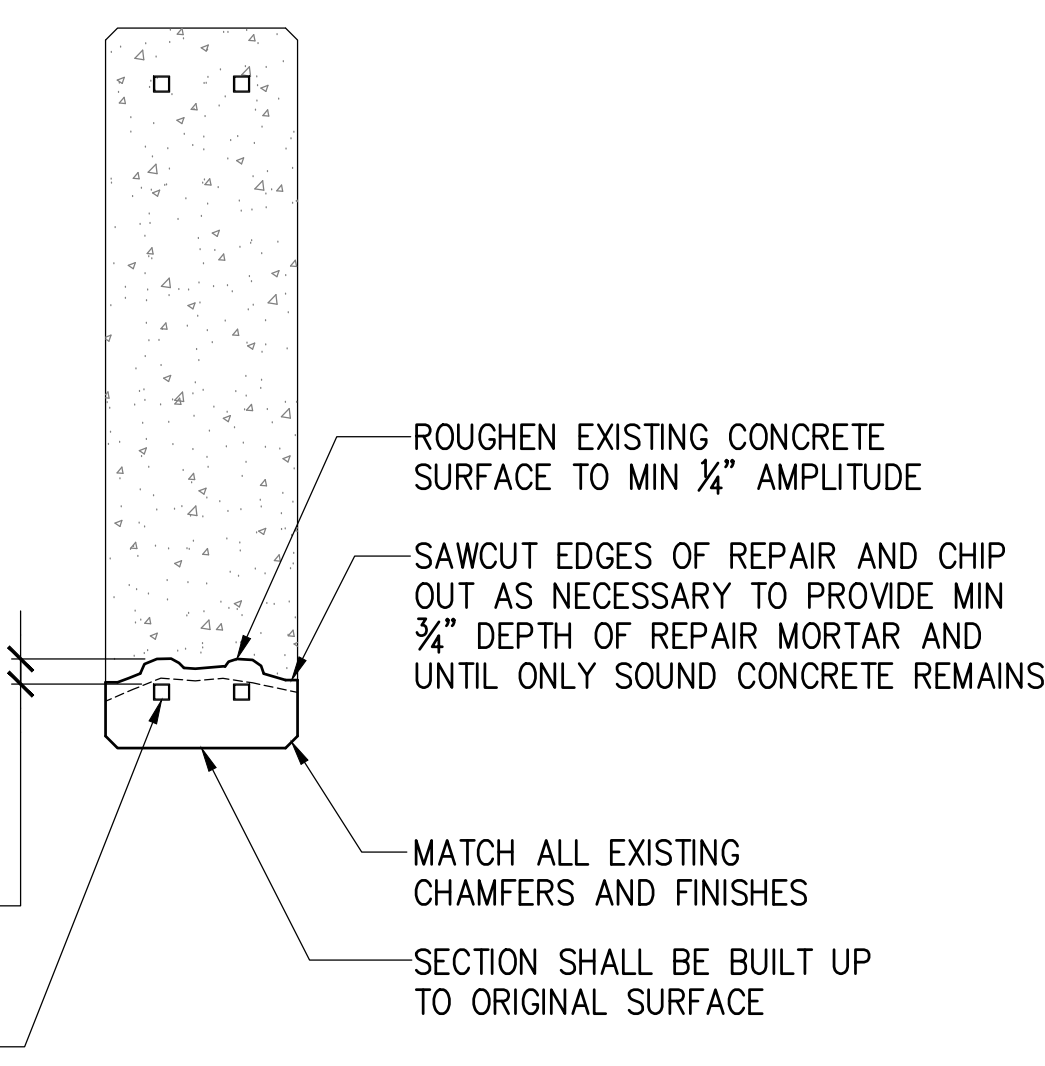

PROVIDE MIN 3/4" CLR AROUND EXISTING REINFORCING STEEL, TYP
CLEAN AND COAT ALL EXPOSED REINFORCING STEEL WITH ANTI-CORROSION COATING

MATCH ALL EXISTING CHAMFERS AND FINISHES
SECTION SHALL BE BUILT UP TO ORIGINAL SURFACE

PARTIAL HAUNCH SPALL REPAIR
(CONDITION AT PIER 1 SHOWN)

REPAIRED CONDITION

FULL HAUNCH SPALL REPAIR
(CONDITION AT PIER 2 SHOWN)

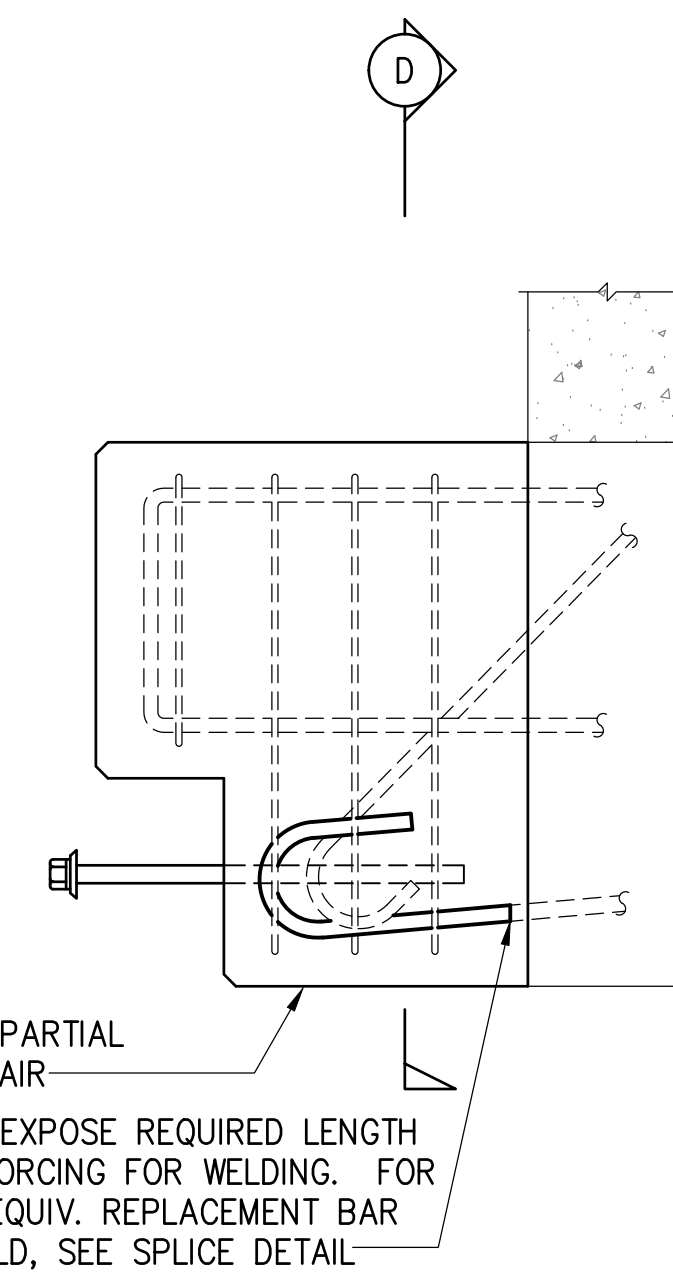

SIDE ELEVATION

D SECTION

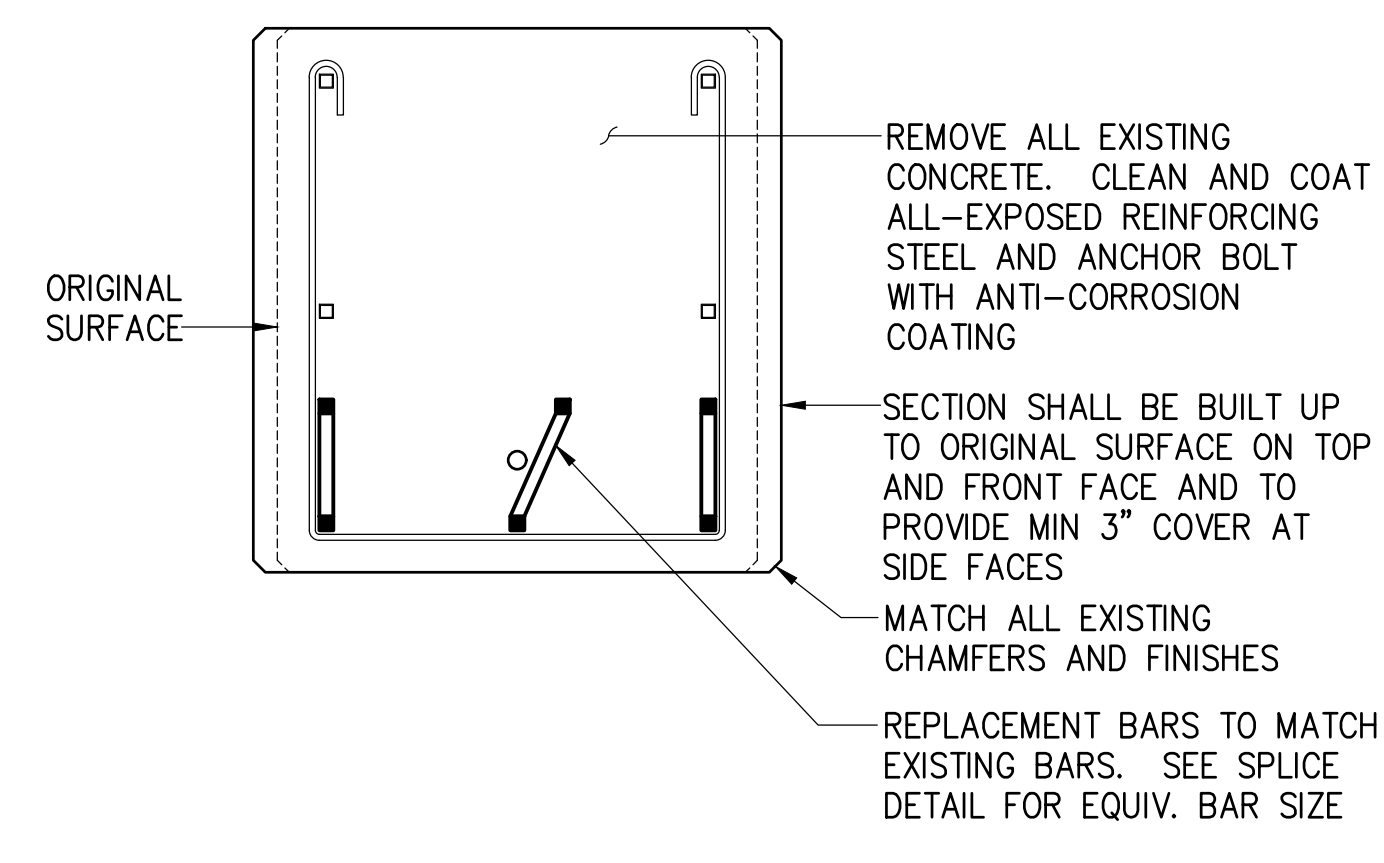

FULL HAUNCH SPALL REPAIR
(CONDITION AT PIER 2 SHOWN)

NOTES:

1. TIRES AND WALES OF FENDER SYSTEM NOT SHOWN FOR CLARITY.
2. HAUNCH REPAIRS SHALL BE PERFORMED PRIOR TO INSTALLING BOTTOM WALE.
3. FRONT, TOP AND BOTTOM SURFACES SHALL BE BUILT UP TO THEIR ORIGINAL SURFACE. CONCRETE REPAIRS ON THE SIDES SHALL BE BUILT UP TO PROVIDE MIN 3" COVER AND TO FACILITATE REPAIR WORK.
4. MATCH ALL EXISTING CHAMFERS AND FINISHES.
5. PAY AREA SHALL BE THE TOTAL REPAIRED AREA ON ALL HAUNCH FACES.
6. LOCATION OF HAUNCH SPALLS ARE NOT SHOWN ON PLANS AND SHALL BE DETERMINED AFTER REMOVAL OF THE EXISTING FENDER SYSTEM.

1 HAUNCH SPALL REPAIR DETAILS
S-11 NOT TO SCALE

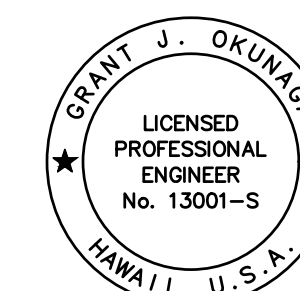

THIS WORK WAS PREPARED BY ME OR UNDER MY SUPERVISION
EXP. 4-30-24
MKE ASSOCIATES LLC

REVISION	DATE	DESCRIPTION	BY	APPROVED
STATE OF HAWAII DEPARTMENT OF TRANSPORTATION HARBORS DIVISION				
JOB TITLE FENDER REPAIRS AT PIER 1, 2 AND TUG PIER KAHULUI HARBOR, MAUI, HAWAII				
SHEET TITLE PIER 1 AND 2 HAUNCH REPAIRS				
DESIGNED BY: GO	DRAWN BY: DL			CHECKED BY: GM
DATE: 04/2023	JOB NUMBER: S30215			SCALE: AS SHOWN
				SHEET S-11 13 of 13 SHTS.